

Installation Guide

Insight Managed WiFi 6 AX3000 Access Point

Model WAX618



NETGEAR, Inc.
350 East Plumeria Drive
San Jose, CA 95134, USA

November 2022

NETGEAR INTERNATIONAL LTD
Floor 6, Penrose Two
Penrose Dock, Cork,
T23 YY09, Ireland

© NETGEAR, Inc., NETGEAR and the NETGEAR Logo are trademarks of NETGEAR, Inc. Any non-NETGEAR trademarks are used for reference purposes only.

Package contents

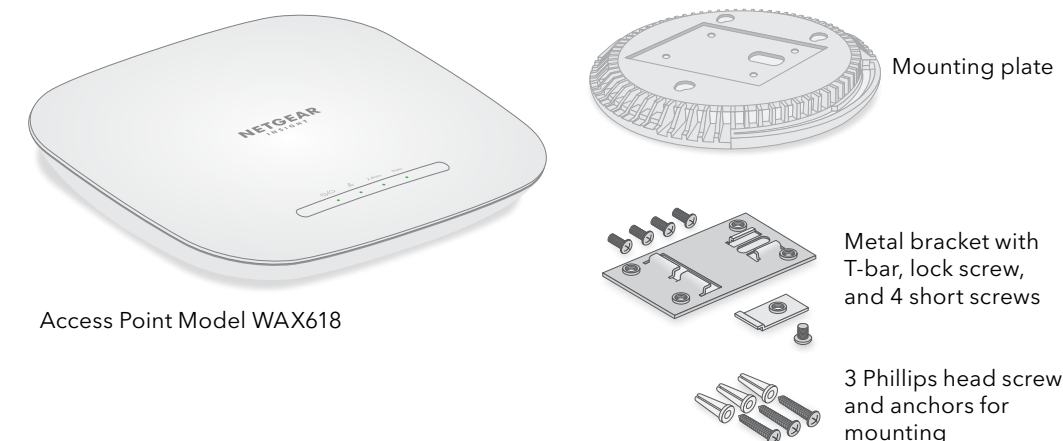

NOTE: You can power up the WAX618 by connecting it to a PoE+ switch, or you can purchase a power adapter separately.

Overview

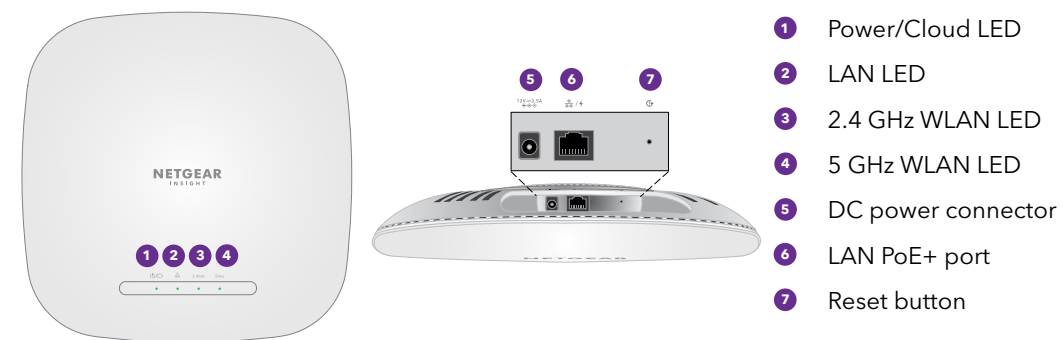

CAUTION: Terms of Use
This device must be professionally installed. It is the installer's responsibility to follow local country regulations including operations within legal frequency channels, output power and DFS requirements. Vendor or Reseller or Distributor is not responsible for illegal wireless operations. Please see Device's Terms and Conditions for more details.

The WAX618 LAN PoE+ port supports Ethernet speeds up to 2.5 Gbps within your LAN when connected to 2.5 Gbps equipment. The preceding figures show a NETGEAR MS510TXUP switch, which supports speeds of 2.5 Gbps and higher, as well as PoE+. If your Internet connection, modem, router, and switch support a speed of 2.5 Gbps, the AP's Internet connection also functions at 2.5 Gbps. Otherwise, the Internet connection functions at 1 Gbps, which is a common speed.

NOTE: The AP receives an IP address from a DHCP server (or a router that functions as a DHCP server) in your network. If your network does not include a DHCP server, the AP uses its default IP address: 192.168.0.100.

1. Connect to power and Internet

Power up the WAX618 access point (AP) by connecting the LAN PoE+ port to a PoE+ switch that supplies 802.3at power (PoE+), or to a power adapter.

Make sure that the AP has Internet connectivity:

- If you connect the AP to a switch, make sure that the switch has Internet connectivity.
- If you use a power adapter to provide power, use an Ethernet cable to connect the LAN PoE+ port on the AP to a router or other network device on a network with Internet connectivity.

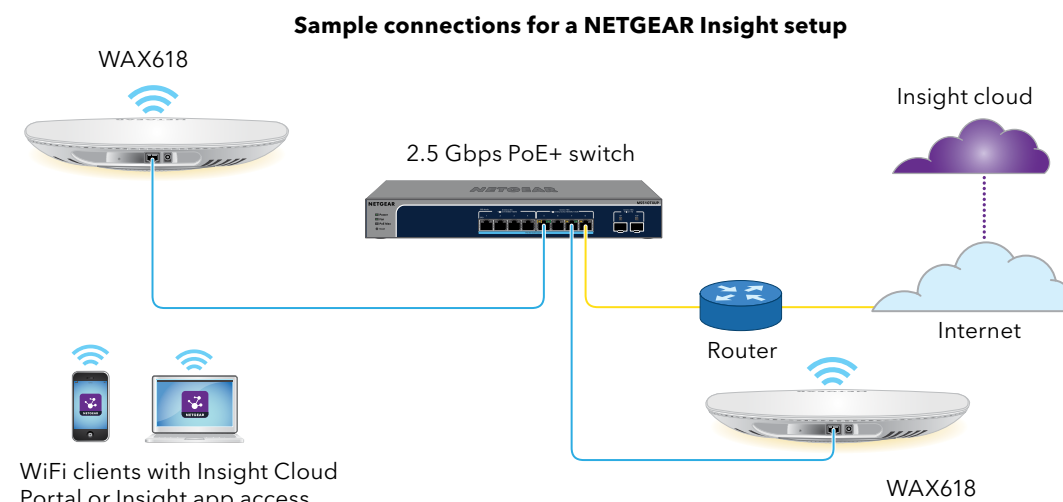

After starting up and during setup, the AP's LEDs can light in these colors:

Power/Cloud		Slow blinking amber: The AP is starting, the firmware is being upgraded, or the AP is trying to get an IP address.
		Solid green: The AP started up, and functions either as a standalone AP or as an Insight-discovered AP that is not currently connected to the Insight cloud.
		Solid blue: The AP functions in Insight mode and is connected to the Insight cloud.
LAN (one of two speed options)		Solid or blinking green: The LAN 1 port detects a speed of 2.5 Gbps.
		Solid or blinking amber: The LAN 1 port detects a speed of less than 2.5 Gbps, such as 1 Gbps (which is a common speed).
2.4 GHz WLAN 5 GHz WLAN		Solid green: The radio is operating without clients.
		Solid blue: The radio has at least one connected client.
		Blinking blue: The radio is processing traffic.

For more information about the LEDs, see the user manual, which you can download by visiting netgear.com/support/download.

2. Getting Started with NETGEAR Insight

Your new Insight-manageable device comes with Insight included, offering remote management of all Insight manageable devices on your network and real-time network status notifications.

Choose the type of account you want:

- Insight Premium** supports a single admin and multiple locations
- Insight Pro** supports multiple admin roles, and organizations in addition to locations

Use either of these options to access Insight and onboard your Insight device:

- Insight Cloud Portal** is your go-to management platform with an extensive set of tools and options including the Topology Viewer. Onboard devices by entering serial numbers and complete configuration in one place. Pro accounts can use bulk upload to onboard multiple devices at once.
- NETGEAR Insight app** is a convenient way to monitor your network on the go, and offers an alternative way to onboard devices by scanning the barcode.

For more information on Insight, visit the NETGEAR website:

- netgear.com/business/services/insight/subscription/
- kb.netgear.com/000061848

3. Log In or Create an Insight account

Your NETGEAR account is also your Insight account. You can use your NETGEAR account credentials to log in as an Insight Premium user, or if you upgrade to an Insight Pro account, as an Insight Pro user.

If you do not already have a NETGEAR Insight account, you can create an account now. For information about creating an Insight Premium or Pro account, or upgrading an existing Insight Premium to a Pro account, visit kb.netgear.com/000044343.

4. Onboard your device to NETGEAR Insight

Choose the method that you want to use to onboard your device:

- [A. Onboard via the NETGEAR Insight Cloud portal](#)
- [B. Onboard via the NETGEAR Insight app](#)

Insight Cloud Portal
insight.netgear.com

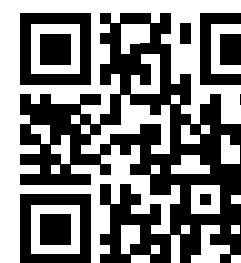

A. Onboard via the NETGEAR Insight Cloud portal

- Make sure that the AP is connected to the Internet.
- On a computer or tablet, scan the QR code for the Insight Cloud Portal or visit insight.netgear.com/.
- Enter the email address and password for your NETGEAR account and click the **NETGEAR Sign In** button.
- For Insight Pro, select the organization to which you want to add the AP.
- Select the network location, or create a new network location.
- Click the **+** (**Add Device**) button.

NOTE: Insight Pro users can either add a single device or add multiple Insight managed devices by uploading a device list as a CSV file.
- In the Add New Device pop-up page, enter the AP's serial number and MAC address, and then click **Go**.
- After Insight verifies that the AP is a valid product, you can optionally change the device name of the AP, and then click **Next**.

When the AP is successfully added to the portal, a page displays a confirmation that setup is in progress.

B. Onboard via the NETGEAR Insight app

- Connect your mobile device to the AP's setup SSID (WiFi network name) using one of these methods:
 - Scan the QR code:** Scan the QR code on the AP label to connect to the setup SSID.
 - Connect manually:** The setup SSID is on the AP label and is shown in the format NETGEARxxxxxx-SETUP, where xxxxxx are the last six digits of the AP's MAC address. The default WiFi passphrase is **sharedsecret**.
- Open the NETGEAR Insight app.
- Enter the email address and password for your account and tap **LOG IN**.
- Add a new network location where you want to add the AP by tapping the **Next button**, and then tapping **OK**. You can also select an existing network location.

The device admin password that you entered for the new network location replaces the existing admin password on all devices that you add to the network location. In most situations, Insight detects the AP automatically, which can take several minutes.
- To add the AP to your network location, do one of the following:
 - If the AP is automatically detected and listed in the Insight Manageable Devices section, tap the icon for the AP, and then tap the **ADD DEVICE** button.
 - If the AP is not automatically detected, or you prefer to use another method to add the AP, tap the **+** icon in the top bar, and do one of the following:
 - Tap the **SCAN BARCODE OR QR CODE** button, and then scan the AP's code.
 - Tap the **Enter Serial Number and MAC Address** link, and then manually enter the AP's serial number and MAC address.
- If prompted, name the AP and tap the **Next** button.

Results

The AP automatically updates to the latest Insight firmware and Insight location configuration. This might take up to 10 minutes, during which time the AP restarts.

The AP is now connected to the Insight cloud-based management platform. The Power/Cloud LED lights solid blue.

If the AP does not show as Connected in Insight, visit kb.netgear.com/000065137.

Mounting options

You can mount the AP to a wall or to a ceiling with a 15/16 in. (24 mm) T-bar, or you can install the AP freestanding on a flat surface.

We recommend that you use a flat Ethernet cable so that the cable fits in the narrow space between the AP and the surface on which it is mounted or placed.

Before you mount the AP, first set up and test the AP to verify WiFi network connectivity.

Mount the AP on a wall

CAUTION: Make sure that the wall is not damaged. For example, water damage can destroy a drywall.

1. Place the mounting plate on the wall.
2. Mark the wall where the mounting holes are.
3. Using a 3/16 in. (4.7 mm) drill bit, drill holes in the wall.
4. Tap each anchor into the wall with a soft mallet until the anchors are flush with the wall.
5. Use the screws to attach the mounting plate to the wall.

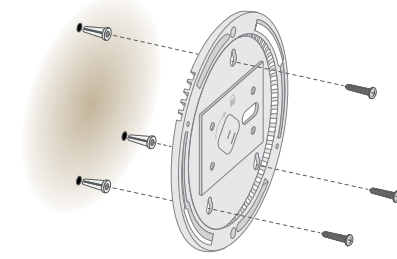

NOTE: Do not insert the screws into the wall without anchors.

6. Connect cables to the AP.
7. Attach the AP to the mounting plate.

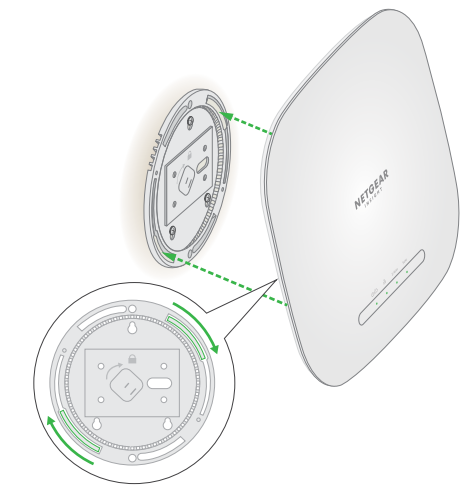

8. Twist the AP clockwise to lock it onto the mounting plate.



Mount the AP to a T-bar

1. Slide the T-bar partially into the metal bracket.
2. Attach the metal bracket to the ceiling bar.
3. Push the T-bar over the ceiling bar.
4. Use the lock screw to lock the metal bracket into place.

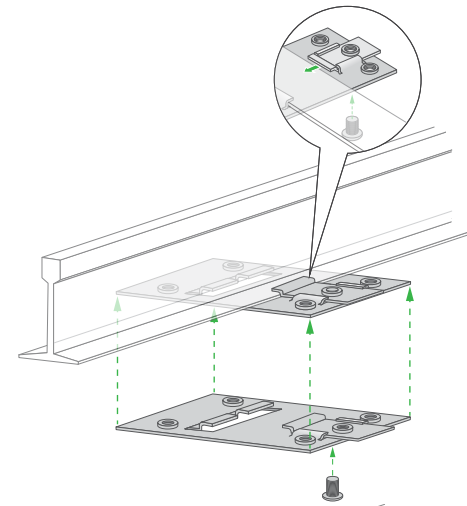

5. Use the four short screws to attach the mounting plate to the T-bar.
6. Connect a PoE cable or power adapter to the AP before mounting.

The AP is designed to be unobtrusive, so it sits flat on the ceiling surface when it is mounted.

7. Hold the AP upside down and attach it to the mounting plate.

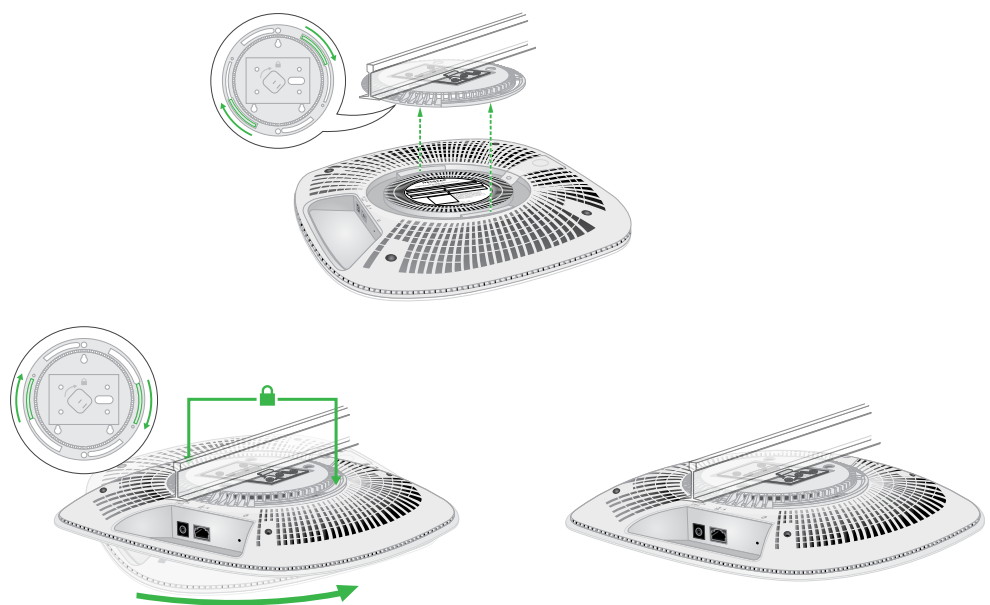

8. Twist the access point clockwise to lock it onto the mounting plate.

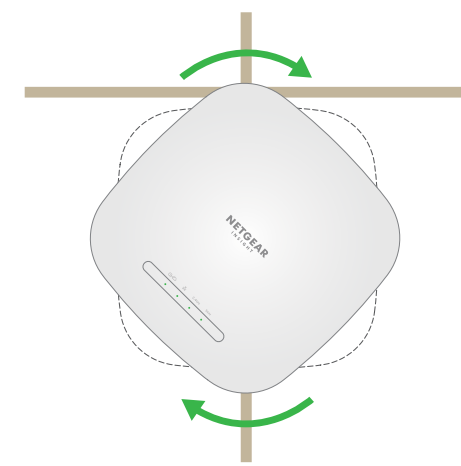

Unmount the AP

CAUTION: Make sure you hold the AP so that it does not drop when you release it from the mounting plate.

1. To find the locking latch, place your thumb on the center of the LEDs, and your finger on the other side of the device, directly opposite the thumb.
2. Press and hold the latch down to release the lock and keep the lock open.

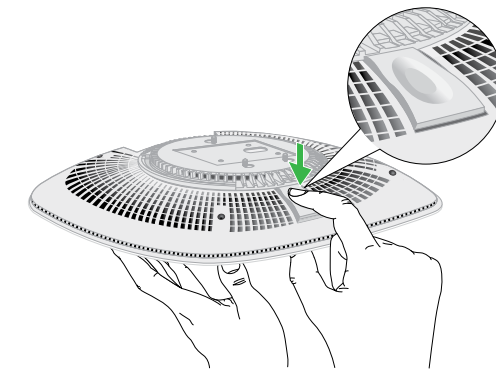

3. Turn the AP counterclockwise until the AP releases from the mounting plate. The mounting plate remains attached to the T-bar or the wall.

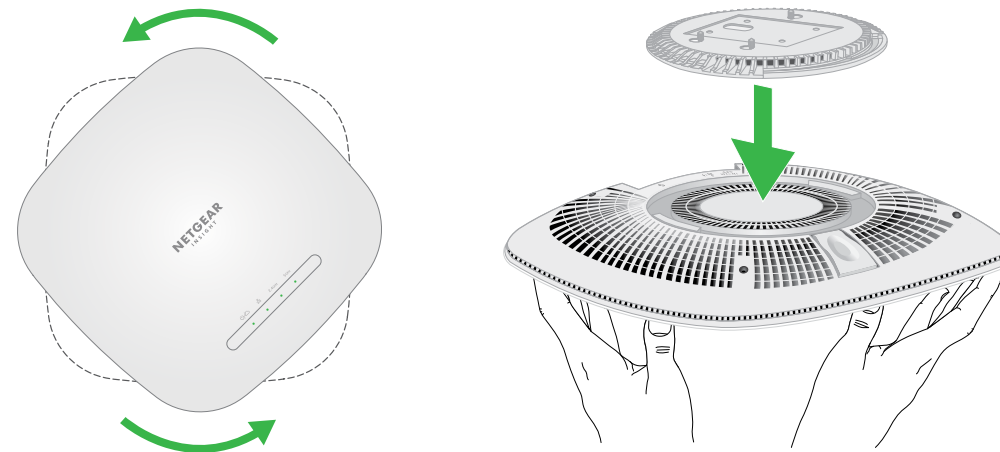

Support and Community

Visit [netgear.com/support](https://www.netgear.com/support) to get your questions answered and access the latest downloads. You can also check out our NETGEAR Community for helpful advice at community.netgear.com.

Regulatory and Legal

Si ce produit est vendu au Canada, vous pouvez accéder à ce document en français canadien à <https://www.netgear.com/support/download/>.

(If this product is sold in Canada, you can access this document in Canadian French at <https://www.netgear.com/support/download/>.)

For regulatory compliance information including the EU Declaration of Conformity, visit <https://www.netgear.com/about/regulatory/>.

See the regulatory compliance document before connecting the power supply.

For NETGEAR's Privacy Policy, visit <https://www.netgear.com/about/privacy-policy>.

By using this device, you are agreeing to NETGEAR's Terms and Conditions at <https://www.netgear.com/about/terms-and-conditions>. If you do not agree, return the device to your place of purchase within your return period.

Do not use this device outdoors. The PoE source is intended for intra building connection only.

Applicable to 6 GHz devices only: Only use the device indoors. The operation of 6 GHz devices is prohibited on oil platforms, cars, trains, boats, and aircraft, except that operation of this device is permitted in large aircraft while flying above 10,000 feet. Operation of transmitters in the 5.925-7.125 GHz band is prohibited for control of or communications with unmanned aircraft systems.