

BFA integrates a unique bank of filters along with a low noise amplifier. Filters and gain can be easily setup locally thru a 4 key navigation buttons and a TFT display or remotely with a data connection through the RF coaxial cable.

Using the latest Wisycom filter technology, BFA gives a full control of RF zones and allows to build flexible and remote controllable antenna systems.

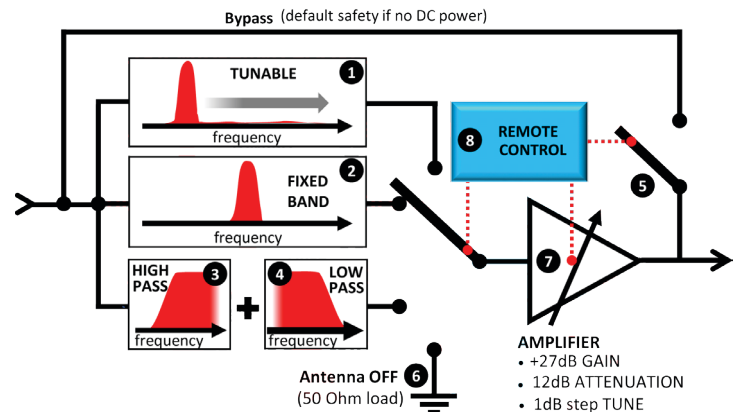

ULTRA WIDEBAND BOOSTER with SELECTABLE FILTERS



- 1 Tunable filter 430-730 (40 MHz wide)
- 2 Fixed band saw filter: 940-960 MHz (Usa) or 1240-1260 MHz (Japan)
- 3 4 High pass filter and low pass filter CASCADE (9 bandpass combinations)
- 5 Bypass line for full band reception (active mode if no DC power for safety)
- 6 Antenna off for zone control
- 7 Gain control from -12 dB to 27 dB
- 8 Remote control with a data link running on coaxial cable

OTHER FEATURES

- Huge reception band: 410-1300 MHz
- Remote controllable thru coax cable
- RF gain from -12 to +27 dBu (1 dB step)
- Tunable filter for interference control
- Antenna off for RF zone disabling
- Fixed band saw filter
- 3 High Pass & 3 Low Pass filters
- Waterproof with gasket sealing
- Pass thru DC selectable for device cascading
- Easy configuration thru a TFT display and 4 key navigation buttons

CONFIGURATIONS

CONNECTOR

B BNC female

N N female

FILTER OPTION

F2 Tunable filter: 430-730 MHz, 40MHz of BW
Selectable Filter HP: 470/520/550 MHz + LP: 617/663/698 MHz (EU/USA)
Fixed Filter: 940 ÷ 960 MHz (USA)

F3 Tunable filter 430-730MHz, 40MHz of Bandwidth,
Selectable Filter HP: 410/470/510 MHz + LP: 600/714/810 MHz (Japan)
Fixed Filter 1240 ÷ 1260MHz (Japan)

F4 Tunable filter: 430-730 MHz, 40MHz of BW
Selectable Filter HP: 470/510/960 MHz + LP: 600/700/1160 MHz (EU/UK)
Fixed Filter: 940 ÷ 960 MHz (USA)

ACCESSORIES & RELATED



Item: CNGT11
RF adapter, N-M/BNC-F

TECHNICAL SPECIFICATIONS

BOOSTER	Control	display menu or remote thru coaxial cable
	Gain	-12÷27 dB typical (1 dB step selection)
	Bandwidth	from 410MHz up to 1260 MHz (depending on the variants)
	Gain flatness	+/-1 dB
	Powering	+12 Vdc/65mA (green led, up to about 15dB of gain), +12 Vdc/110mA (blue led, more than about 15dB of gain)
FILTER	Operating voltage range	9.5 ÷ 16 Vdc
	Bypass/OFF	Full bandwidth Bypass (0.8dB attenuation) and RF OFF function
	Tunable	430 ÷ 730 MHz (UHF), 40MHz of BW
MECH.	Fixed	940-960 MHz (for USA) or 1240 ÷ 1260MHz (for Japan)
	Selectable band pass filter	HP 410/470/510 MHz, LP 600/700/810 MHz (other see filter option)
	Connectors	BNC-F (BFA-B), N-F (BFA-N)
	Display	TFT – transfective (176 x 176 pixels, RGB)
	Weight	250 g
	Size	120 mm(L) x 48 mm(H) x 30 mm(D)