

# MTP61 USER MANUAL



MULTI-BAND WIRELESS  
PROFESSIONAL MINIATURE  
TRANSMITTER

Rev.01 (ref. FW 1.4.0)

Date: 28th August 2023

**PRODUCT OVERVIEW**

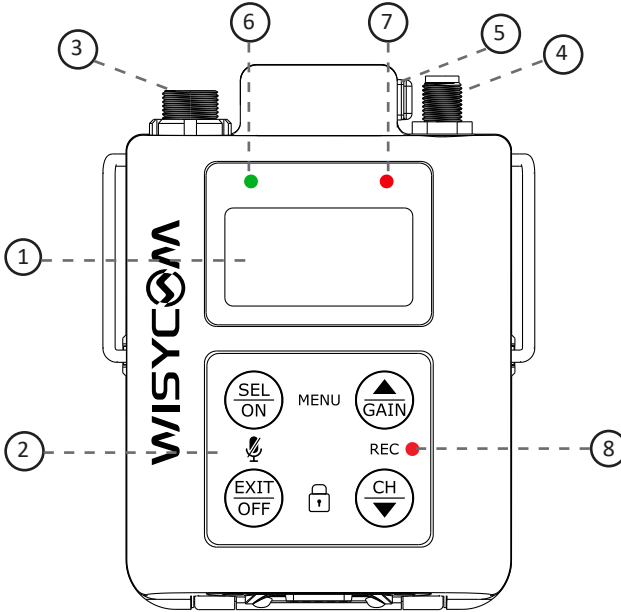

- |                                   |                              |
|-----------------------------------|------------------------------|
| 1. OLED white display (128x64 px) | 6. LED1 for audio            |
| 2. 4 setup buttons                | 7. LED2 for RF and battery   |
| 3. MIC connector (LEMO 3pin)      | 8. LED3 for recording        |
| 4. Antenna connector (SSMA)       | 9. battery compartment       |
| 5. battery compartment button     | 10. Magnetic Connector 5 pin |

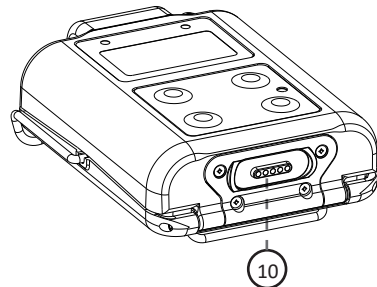
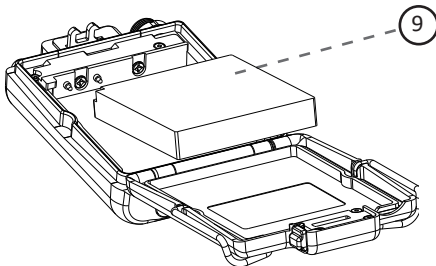
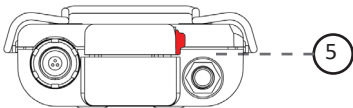

## LED INDICATIONS

- LED 1 - audio indication
  - Green unit is modulating regularly
  - Red audio is peaking
  - OFF (grey) audio is muted
- LED 2 - RF and battery indication
  - Red when transmission is OFF
  - Green when transmission is ON
  - Red slow blink when battery is < 25%
  - Red fast blink when battery is < 12%
  - OFF (grey) when MTP61 is OFF
- LED 3 - recording
  - OFF (grey) when recording is OFF
  - Red when recording is active

When MTP61 is inserted in BCL61 battery charged:

- LED 1 - recharging status
  - OFF (grey) when no recharging
  - Green when is recharging
  - Blue when recharge is completed

## SETUP CONTROL

Use the 4 front buttons to navigate the menu and quickly setup:

### SEL/ON:

- Hold to switch ON the device.
- Push together with GAIN/UP to enter the main MENU.
- Long press for RF activation
- When in menu single push to save and confirm selections.

### UP/GAIN:

- Push to scroll up while in the menu
- Short press for quickly access to GAIN setup (from Home Screen)

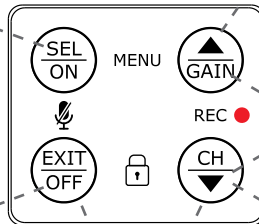

### GAIN + CH:

To enter on RECORDING setup

### EXIT/OFF:

- Long press to switch the unit OFF
- Short press to step back into menu
- Long press to switch ON the transmitter without RF output enabled

### DOWN/CH:

- Push to scroll down while into the menu
- Short press for quickly access to CHANNEL setup (from STATUS menu)

### EXIT + CH:

To lock/unlock front panel

## POWERING UP

Push SEL/ON button for few seconds to switch on MTP61 and activate wireless transmission.(RF Power has to be previously enabled).

Push EXIT/OFF button for few second to switch on MTP61 without the activation of wireless transmission.

## STATUS menu

After the power up phase, the Status menu is showed where major info are displayed:

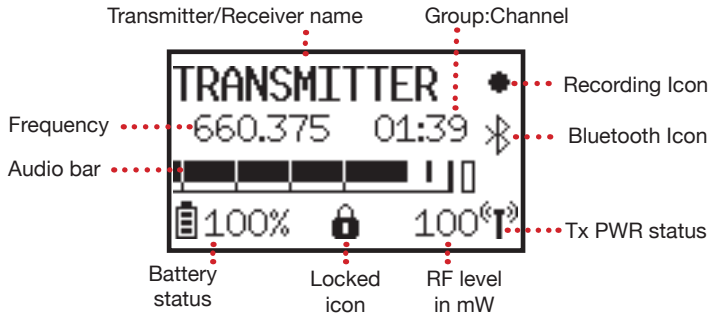

From the status menu it is possible to access the main functions of the transmitter thanks to the quick selection keys:

- **GAIN** to change the audio gain level
- **CH** to change group / channel / frequency
- **UP+DOWN (REC)** to start / stop recording or JAM external Timecode
- **EXIT+DOWN (LOCK)** to lock / unlock the display
- **SEL+EXIT (MUTE)** to mute the audio

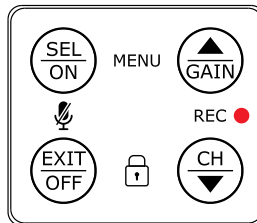

## SETUP menu

Push **SEL+UP** buttons to enter on the Setup menu.

Using **UP/DOWN** button all menus can be accessed in sequence and change the parameters value. Each change is immediately set on MTP61, it is not necessary to confirm the modification. Push **EXIT** button to exit from menu.

If no button is pressed for **60 seconds**, the display is locked automatically to prevent accidental changes and the locked icon appears at the bottom of the display (this setting can be changed via the Settings> Display> Auto-lock menu).

To unlock the display push EXIT and DOWN buttons together.

## QUICK SETUP

- connect the microphone to the LEMO 3pin connector
- power on the MTP61
- enable BT sync and synchronize with Wisycom receiver
- connect the correct antenna (see code on RF > Antenna menu)
- set Mic Mode (Audio > Mic Mode menu)
- set the gain, with the maximum input signal, avoiding the peak on the audio bar. TRY TO SETUP TO HAVE A MAX PEAK HOLD BAR CLOSE TO -6dB.
- configure power level (RF > RF Power)
- jam the TC and activate recording (REC)

## OPERATING MENU

BT sync			
PRESET	Load	U1--/U2--/DPA... /Factory	
	Save	U1--/U2--/DPA...	
	Active	Factory/...	
RF	Freq	Frequency/GR/CH	
	RF Power	OFF/10/10L/20/20L/50/100mW	
	Antenna	507/560...	
AUDIO	Gain	-20 to +26 dB	
	Ch. Mod.	Wide/Narrow	
	HPF	FLAT/45/60/80/120/170/240	
	Mic Mode	2W/2W+B/3W/AUX (only 2W/2W+B for DPA connector)	
	PTT	Disabled/Mute/ON (no PTT menu for DPA connector)	
	Phase	0/180	
	Limiter	OFF/ON	
	Cal Tone	Cal. Tone	OFF/ON
		Frequency	1000 Hz /400 Hz
		Level	-20 dB
RECORDER	REC	OFF/ON	
	Elapsed	hh:mm:ss	
	Remaining	hh:mm:ss	
	Timecode	hh:mm:ss	
	TC setup	Jam	OFF/Running
		Source	Wire/Tentacle
		TC	hh:mm:ss
		TC ext	hh:mm:ss
		FPS	23.98/24/25/29.97/29.97DF/30/30DF/50/59.94/59.94DF/60
		Ubits	SMPTE/mm.dd.yy/dd.mm.yy/mm.dd.yyyy/dd.mm.yyyy
		Time	hh:ss:mm
	Date	mm:dd:yyyy	
	Bit Depth	24/32 bit	
	SD Card	Name by	Sequence/Scene&Tk
		Scene	1-99
		Shot	none/A-Z
Take		1-99	
Format		"warning..."	

SETTINGS	BT	Pwr	Yes/No	
		Mode	Wisycom	
		Pairing	Yes/No	
		Passcode	Yes/No	
		Reset Dev	...	
	Name	Transmitter (8 char)		
	Battery	% / time		
	LED	Brightn.	OFF, from 1 to 5	
		Mode	Full/Alarms/PTT	
	Display	Brightn.	from 1 to 5	
		LOW	from 5 to 60 sec	
		OFF	from 10 to 120 sec (10 sec step) / OFF	
Direction		Up/Down		
Auto-lock		60 sec/30 sec/15 sec/OFF		
INFO	FW	Version	v1.4.0	
		BL	v1.3.0	
		DSP	vX.Y	
	Serial	09900004		
	Range	470-1075		
	Band	B1		
	HW	Country	US	
		Main rev.	0:02	
		Main opt.	1	
		Options	...	
	Profile	US/EU/CA		
	STD	depending on the country		
	Battery	Level	90%	
		Time	6h:47m%	
		Voltage	3,79V	
		Current	194mA	
	Temp	26 C		
Model	MTP61			
Alarms	0			

## BT sync

Enable BT sync to do a synchronization via Bluetooth to Wisycom receiver.

This function is compatible with the following Wisycom receivers:

- MCR54 (fw v2.4.0)
- MCR54-DUAL (fw v2.4.0)
- MRK980 (new fw in progress).

During the synchronization process the receiver passes to the MTP61 the following parameters:

- tuning frequency, group and channel
- type of compander
- name of the receiver

MTP61 sets these parameters accordingly and passes to the receiver the modulation type (WB/NB). If some parameter is not compatible between MTP61 and receiver, a warning appears on receiver display.

## PRESET menu

MTP61 can recall configuration presets:

- "Factory" recalls the Wisycom factory configuration.
- "USER" (U1, U2..., U8) recalls the configuration saved by menu

## RF menu

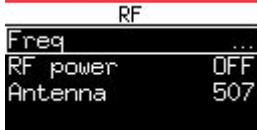

**RF** to change of Group/Channel/Frequency



Check the maximum power level that can be selected based on the power profile configured in your transmitter\*

The MTP61 has 40 groups of 60 channels each. Normally this is too much for wireless micro-phones applications.

Connecting with computer with WISYCOM MANAGER software, it is possible to **hide** single channels or even complete groups of channels: once hidden those items are not shown anymore on the channels or groups selection. To show channels or groups hidden use again the WISYCOM MANAGER software.

Using this software it is also possible to **lock** channels or groups. When a channel is locked, it is not possible to change the frequency from the display menu of the transmitter. Locking a group means that all channels are locked. When a channel or a group are locked, at the left of the frequency will appear a lock icon to indicate that the frequency is not editable.

**RF Power** to set power level (10, L10, 20, L20, 50, 100 mW, OFF to disable transmission). LED2 becomes fixed red when the transmitter is tuned and RF Power is set to OFF, becomes fixed green when the transmitter is tuned and RF power isn't OFF. Increasing the power level increases the coverage but also increases the power consumption and in small environments it can cause intermodulation problems. Use L10 or L20 levels to set 10 mW or 20 mW of power

\*The transmitter is factory programmed with a power profile capable of complying with the regulations in force in the country of sale of the MTP61. this profile limits the selectable frequencies and the maximum power level allowed.

and activate Linear technology.

Linear is suggested for situations where spectrum is limited and frequencies need to be placed in close proximity. This allows to operate EQUALLY SPACES frequency (placed every 400kHz (Wide-band) or 200kHz (Narrowband | High Density)

Note that power consumption of L10 and L20 levels are comparable to the consumption of the level 100 mW.

**Antenna** to check what model of antenna connect. The model is reported on the antenna cap (e.g. 950). This number is approx. the frequency of the middle of the band.

Label	Band MHz
507	470-547
590	547-663
552	510-595
646	595-698
710	663-760
796	760-832
808	806-810
950	940-960
1K1	960-1160
1K2	1240-1260



NOTE: with increasing frequency the length of the antenna decreases (therefore use short antenna for high frequencies, long antenna for low frequencies)

## AUDIO

**Gain** to set the sensitivity of the audio input.

You can access this menu directly from the status menu by pressing the UP / GAIN button.

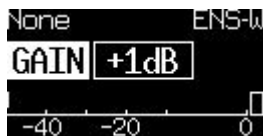

To help proper audio gain setting, an audio bar is supplied (with maximum peak indicator) indicating the headroom to audio peak (0 dB , nominal deviation 40KHz).

Set the gain with the maximum input signal, avoiding the peak on the audio bar.

TRY TO SETUP TO HAVE A MAX PEAK HOLD BAR CLOSE TO -6dB

Gain settings is from -20 to +26dB (1dB step).

**Ch. Mod.** menu defines the type of modulation between Narrowband or Wideband. This reduces or expands the spectrum occupation of the MTP61 Transmitter.

When the transmitter is set to WideBand the audio bandwidth is limited to 20 KHz and the peak deviation is set to  $\pm 56$  kHz so that the occupied bandwidth is approx. 150 KHz.

When the transmitter is set to NarrowBand the audio bandwidth is limited to 17 KHz and the peak deviation is set to  $\pm 35$  kHz so that the occupied bandwidth is approx. 100 KHz.

Switching to Narrowband provides an additional 3dB of RF Sensitivity on the receiver.

Note: make sure to set the receiver channel to the same modulation setting of the transmitter.

Ex. Wideband or Narrowband.



**HPF** menu to set High Pass Filter of the audio signal. Different filters are available (FLAT means no filter)

**Mic Mode** menu set the audio mic connection.

Following Mic mode can be setup:

- 2W (2 wires): (PTT is possible) for external audio input
- 2W+B (2 wires + bias): (PTT is possible) for most 2 wires MIC
- 3W (3 wires): (no PTT) for most 3 wires MIC
- AUX: high impedance input

*NOTE: MTP61 is not compatible with PHA60 phantom adapter.*

**PTT** menu allows to configure the behaviour of PTT accessory when it is pushed.

If PTT is set to Mute, the audio is muted when the Push to Talk button is pushed.

If PTT is set to ON, Wisycom receiver is able to do an audio routing according to Tone squelch matrix set on the receiver (see receiver user manual for more details).

**Limiter** to enable or disable the limiter function. When limiter is enable and the audio input level is too high (level on the audio bar arrives to the peak) the transmitter adapt automatically the audio level to avoid distortion.

**Cal. tone** to activate the calibration tone.

The CALIBRATION TONE function generates a tone at specific frequencies (400Hz or 1000 Hz) at -20dB level on the audio input.

*Calibration tone Example – DPA 40xx would typically use 2W+ for 2 wire plus bias giving the 5V required for the mic. A good starting place for this could be -6dB for starting with an interview. This setting allows for a range from -40dB to +26dB*

*Example – Instrument typically for use with instruments that have a higher output level. Suggested starting gain is -23dB.*

**RECORDING**

MTP61 is equipped with 64 GB micro SD memory card (industrial grade heavy duty).

The MTP61 records on SD card exFAT formatted.

To format the card enter on the “Recorder > SD Card > Format” menu.

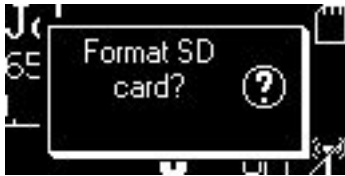

Press “SEL/ON” to format the card and wait some seconds until the process is completed. DO NOT turn off the transmitter during formatting!

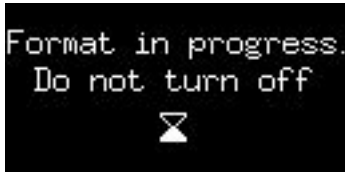

If the card is detected correctly, the card icon appears at the top right of the MAIN menu



..... SD card Icon

To start recording enter on the Recorder menu and set REC to ON or use the recording short cut pushing UP and DOWN arrows together and press START.

If during recording accidentally the battery dies, the transmitter automatically save the file up to 15 seconds prior the event. If the transmitter restarted with the same SD card in, the recording file is completely recovered without any data loss.

**NOTE:**

MTP61 fully support EX-FAT (extended Fat) with a storage limit of 2 TB.

Recorded audio is full quality not compressed.

*example:*

*24 bit is 3 bytes with 48000 samples/sec.*

*That makes 144000 bytes/sec.*

*That makes around 520 Mb/hour.*

**Recording short cut:**

Push UP and DOWN arrows together to enter on the quick RECORDING menu.



Use arrows to move the cursor between START/STOP and JAM function.  
Push SEL button to activate the function.

The MTP61 records 32-bit float RF64 WAV (over 4 GB) files at 48 kHz sampling rates.  
Bit Depth can be change to 24 bit using "Recorder > BitDepth" menu.

The file name format is "Transmitter name-<sequential number>.WAV or Transmitter name\_<Trace number><Shot>\_<sequence number>.WAV according to the Name setting on Recorder>SD Card menu.

All files are recorded in a folder with the transmitter name.

*example:*

*Transmitter name: PAUL LEE*

*Recorder trace 4 is saved in the folder PAUL LEE with the name PAUL LEE\_04.wav;*

*Transmitter name: Transmitter*

*Recorder trace 4, shot 0, sequence 02 is saved in the folder Transmitter with the name Transmitter\_04A\_02.wav*

**Jamming Timecode**

The MTP61 accepts timecode from external LTC sources by wire or via Bluetooth with Tentacle Sync-E. Set the proper way in the "Recorder > TC Setup > Source" menu.

The timecode value and frame rate are taken from incoming LTC source.

Jammed timecode values are held for up to six hours after powering off (with batteries inside), and up to one hour after the battery has been removed. This allows for time to swap batteries without having to re-jam timecode.

Wire Jam:

- connect a valid LTC source to the LEMO audio connector of MTP61
- enter on the Recorder>TC setup menu and set Jam to ON or use the recording short cut pushing UP and DOWN arrows together and active JAM function.

*Pinout for TC audio cable:*

*Audio cable with LEMO 3pin to Stereo jack connector:*

*- LEMO pin 3 (AF) to the Left (tip) of Stereo jack*

*- LEMO pin 1 (GND) to the Ground (sleeve) of Stereo jack*

*Audio cable with LEMO 3pin to BNC connector:*

*- LEMO pin 3 (AF) to the BNC center pin*

*- LEMO pin 1 (GND) to the BNC shell*

Bluetooth Jam (with Tentacle sync E):

- place the TC source (Tentacle sync E) to the MTP61
- use the recording short cut pushing UP and DOWN arrows together and active JAM function or enter on the Recorder>TC setup menu and set Jam to Running
- wait until the jam completed

*NOTE: It is not necessary to activate Bluetooth beforehand. If the Bluetooth is inactive, the Jam procedure activates it momentarily until the operation is complete.*



## SETTINGS

Use this menu to

- power on or off the Bluetooth interface
- configure transmitter's name
- configure battery, LED and display

## INFO

Use this menu to check information about the transmitter (serial number, frequency range, firmware and hardware version) and its status (voltage, temperature and alarms).

## BATTERY

MTP61 works with Lithium-ion battery Model CS-BCE10 Part No. CGA-S008E (3.7V, 1050 mAh) Battery status can be checked on internal OLED display or looking the LED2 status on front. Through the "Settings> Battery" menu, it is possible to set whether to display the battery status as a percentage or as an estimate of the remaining time.

## AUDIO CONNECTOR



3 PIN LEMO CONNECTOR (use FVB.00.003.NLN on Mic)

Mic Mode	Pinout	Impedance
2W (2 Wire)	1 = GND 3 = AF	7,15 KΩ
2W+B (2 Wire + Bias)	1 = GND 3 = AF + 5 V	3,9 KΩ
3W (3 Wire)	1 = GND 2 = 5 V 3 = AF	7,15 KΩ
AUX (high impedance input)	1 = GND 3 = AF	36 kΩ

## TECHNICAL SPECIFICATION

Frequency range	from 470 to 1260 Mhz, depends on the country (see Configurations)
Switchable channels	2400 managed in 40 groups of 60 frequencies completely user programmable
Switching-window	Up to 362 MHz, depending on band (see Configurations)
Frequencies	Quartz PLL frequency synthesizer circuit (5 kHz step)
Frequency error	±2.5 ppm, in the rated temperature range
RF Power	10mW/ L10 W/ 20 mW/ L20 mW / 50 mW /100 mW
Antenna connector	SSMA
Modulation	Wideband and Narrow-band with DSP based digital signal processing
Nominal deviation	±40 kHz Wideband / ±25 kHz Narrowband
Peak deviation	±56 kHz Wideband / ±35 kHz Narrowband
Spurious emissions	< 2 nW
Telemetry feature	TX transmits also a digitally modulated sub-carrier, suitable for: <ul style="list-style-type: none"> <li>• tone-squelch operating</li> <li>• remote battery monitoring</li> <li>• optional PTT (push to talk) operation</li> </ul>
Noise Reduction system	ENS - Wisycom ultra-high performance compander
AF bandwidth	Audio frequency response (dBA): <ul style="list-style-type: none"> <li>• 45 Hz ÷ 17 KHz (3dB) in <b>NarrowBand mode (NB)</b></li> <li>• 45 Hz ÷ 20 KHz (3dB) in <b>WideBand mode (WB)</b></li> </ul>
Distortion	< 0.3 % (0.15 % typ.)
SND/D ratio (Analogue)	typ. 115 dB (A)rms with 40 kHz deviation; typ. 121 dB (A)rms with 56 kHz deviation Wideband typ. 115 dB (A)rms with 25 kHz deviation; typ. 121 dB (A)rms with 35 kHz deviation Narrowband
Audio input connector	LEMO 3pin
Audio input level	from -40 dBu (12mVrms) to 6 dBu (1.55 Vrms) adjustable in 1 dB steps
Max input level	+6 dBu (1.55 Vrms) at clipping
Storage media	internal 64 GB micro SD memory card (industrial grade heavy duty)
Time code	Linear Timecode decoding
Bit rate	24 bit / 32 bit
Sampling rate	48 kHz
Managing interface	Bluetooth 5.2 low energy long range, proprietary waterproof magnetic connector 5 pin (USB HS +power +LTC)
LED	3 RGB LEDs (red, green and blue) for audio, RF, battery status and battery charger
Battery level indication	percentage or minute/second
PTT function	Pin 3 of AF connector can be controlled via an external PTT button
Display	High contrast OLED white display (128 x 64 pixels)
Power supply	Cameron Sino Lithium-ion battery Model CS-BCE10 Part No. CGA-S008E (3.7V, 1050 mAh)
Power consumption	250mA@ 3V average (display off, 100mW power)
Battery life	approx. 8 hours @ 10mW
Temperature range	-10 ÷ +55 °C
Dimensions	66,8mm x 47mm x 17mm (HxWxD) without clip
Weight	Approx. 72 g. without battery, 94 g. with battery

## CONFIGURATION

MTP61-<Contry range>

Country range:

**EU:** 470-832 MHz, Max power 50mW

**EUX:** 470-832 MHz, Max power 100mW

**UK1:** 470-663 MHz, Max power 100mW + 960-1075 MHz, Max power 50mW

**UK2:** 510-698 MHz, Max power 100mW + 960-1075 MHz, Max power 50mW

**US\*:** 470-608 MHz,Max power 100mW+614-663 MHz,Max power 20mW+940-960 MHz,Max power 100mW

**CA:** 470-608 MHz,Max power 100mW+614-663 MHz,Max power 20mW+940-960 MHz,Max powe 100mW

**KR:** 510-698 MHz, Max power 100mW + 925-937,5 MHz, Max power 10mW

**JPx:** JP1 (660-714 MHz, Max 10mW), JP2 (806-810 MHz, Max 10mW), JP3 (1240-1260 MHz, Max 50mW)

**MX:** 470-608 MHz, Max power 100mW+614-832 MHz,Max power 100mW

*\*Simultaneous recording and wireless transmission is not available on transmitters sold in the USA*

## ANTENNA RANGE & CONFIGURATION

Ant Label	Code	Band MHz
507	<b>AWSS-507</b>	470-547
590	<b>AWSS-590</b>	547-663
552	<b>AWSS-552</b>	510-595
646	<b>AWSS-646</b>	595-698
710	<b>AWSS-710</b>	663-760
796	<b>AWSS-796</b>	760-832
808	<b>AWSS-808</b>	806-810
950	<b>AWSS-950</b>	925-960
1k1	<b>AWSS-1K1</b>	960-1160
1K2	<b>AWSS-1K2</b>	1240-1260

MTP61 is supplied with

- 2 Lithium battery Model CS-BCE10
- 1 wire belt clip (BCLW61)
- antenna kit: according to the configuration of MTP61 the following kit antennas are supplied:

**MTP61-US and MTP61-CA**

AWSS-507 (470-547 Mhz)

AWSS-590 (548-663 Mhz)

AWSS-950 (940-960 Mhz)

**MTP61-UK1**

AWSS-507 (470-547 Mhz)

AWSS-590 (548-663 Mhz)

AWSS-1K1 (960-1160 Mhz)

**MTP61-KR**

AWSS-552 (510-595 Mhz)

AWSS-646 (595-698 Mhz)

AWSS-950 (940-960 Mhz)

**MTP61-UK2**

AWSS-552 (510-595 Mhz)

AWSS-646 (595-698 Mhz)

AWSS-1K1 (960-1160 Mhz)

**MTP61-EU / MTP61-EUX / MTP61-MX**

AWSS-507 (470-547 Mhz)

AWSS-590 (548-663 Mhz)

AWSS-710 (663-760 Mhz)

AWSS-796 (760-832 Mhz)

**MTP61-JP1/JP2/JP3**

AWSS-710 (660-760 Mhz) or

AWSS-808 (806-810 Mhz) or

AWSS-1250 (1240-1260 Mhz)

## MANUFACTURER DECLARATIONS

In compliance with the following requirements: RoHS Directive (2002/95/EC)



WEEE Directive (2002/96/EC)

Please dispose of the diversity transmitter at the end of its operational lifetime by taking it to your local collection point or recycling center for such equipment



Battery Directive (2006/66/EC)

The supplier batteries or rechargeable batteries can be recycled. Please dispose of them as special waste or return them to your specialist dealer. In order to protect the environment, only dispose of exhausted batteries.



### ITALY ONLY

Obblighi di informazione agli utilizzatori

ai sensi dell'art. 13 del Decreto Legislativo 25 luglio 2005, n. 151 "Attuazione delle Direttive 2002/95/CE, 2002/96/CE e 2003/108/CE, relative alla riduzione dell'uso di sostanze pericolose nelle apparecchiature elettriche ed elettroniche, nonché allo smaltimento dei rifiuti"

#### Smaltimento di apparecchiature elettriche ed elettroniche di tipo professionale



Il simbolo del cassonetto barrato riportato sull'apparecchiatura o sulla sua confezione indica che il prodotto alla fine della propria vita utile deve essere raccolto separatamente dagli altri rifiuti.

La raccolta differenziata della presente apparecchiatura giunta a fine vita è organizzata e gestita dal produttore. L'utente che vorrà disfarsi della presente apparecchiatura dovrà quindi contattare il produttore e seguire il sistema che questo ha adottato per consentire la raccolta separata dell'apparecchiatura giunta a fine vita.

L'adeguata raccolta differenziata per l'avvio successivo dell'apparecchiatura dismessa al riciclaggio, al trattamento e allo smaltimento ambientale compatibile contribuisce ad evitare possibili effetti negativi sull'ambiente e sulla salute e favorisce il re-impiego e/o riciclo dei materiali di cui è composta l'apparecchiatura.

Lo smaltimento abusivo del prodotto da parte del detentore comporta l'applicazione delle sanzioni amministrative previste dalla normativa vigente.

#### Smaltimento batterie usate



Questo prodotto può contenere batterie. Questo simbolo apposto sulle batterie significa che non possono essere smaltite insieme a normali rifiuti domestici, bensì devono essere depositate negli appositi punti di raccolta delle batterie.

Iscrizione al Registro A.E.E. n. IT0910000006319



## Statements regarding FCC and Industry Canada

The Wisycom microphone pocket transmitter model MTP61 complies with the following requirements: FCC (Federal Communications Commission) Part 74.

Operation is subject to the following two conditions:

- (1) This device may not cause harmful interference, and
- (2) This device must accept any interference received, including interference that may cause undesired operations.

Changes or modification not expressly approved by the party responsible for compliance could void the user's authority to operate the equipment.

This device complies with part 15 of the fcc rules.

Operation is subject to the following two conditions:

- (1) this device may not cause harmful interference, and
- (2) this device must accept any interference received, including interference that may cause undesired operation.

Note: the grantee is not responsible for any changes or modifications not expressly approved by the party responsible for compliance. such modifications could void the user's authority to operate the equipment.

NOTE: This equipment has been tested and found to comply with the limits for a Class B digital device, pursuant to part 15 of the FCC Rules. These limits are designed to provide reasonable protection against harmful interference in a residential installation. This equipment generates uses and can radiate radio frequency energy and, if not installed and used in accordance with the instructions, may cause harmful interference to radio communications. However, there is no guarantee that interference will not occur in a particular installation. If this equipment does cause harmful interference to radio or television reception, which can be determined by turning the equipment off and on, the user is encouraged to try to correct the interference by one or more of the following measures:

- Reorient or relocate the receiving antenna.
- Increase the separation between the equipment and receiver.
- Connect the equipment into an outlet on a circuit different from that to which the receiver is connected.
- Consult the dealer or an experienced radio/TV technician for help.

EN

This device complies with Industry Canada license-exempt RSS-123 and RSS-210 standard. Operation is subject to the following two conditions: (1) this device may not cause interference, and (2) this device must accept any interference, including interference that may cause undesired operation of the device. This radio transmitter IC: 11967A-MTP61 has been approved by Industry Canada to operate with the antenna types listed below with the maximum permissible gain and required antenna impedance for each antenna type indicated. Antenna types not included in this list, having a gain greater than the maximum gain indicated for that type, are strictly prohibited for use with this device.

FR

Le présent appareil est conforme aux CNR d'Industrie Canada applicables aux appareils radio exempts de licence RSS-123 et RSS-210.

L'exploitation est autorisée aux deux conditions suivantes:

- (1) l'appareil ne doit pas produire de brouillage, et
- (2) l'utilisateur de l'appareil doit accepter tout brouillage radioélectrique subi, même si le brouillage est susceptible d'en compromettre le fonctionnement.

Le présent émetteur radio IC: 11967A-MTP61 a été approuvé par Industrie Canada pour fonctionner avec les types d'antenne é numérés ci-dessous et ayant un gain admissible maximal et l'impédance requise pour chaque type d'antenne. Les types d'antenne non inclus dans cette liste, ou dont le gain est supérieur au gain maximal indiqué, sont strictement interdits pour l'exploitation de l'émetteur.

Antenna types (50 Ohm impedance, max gain 2.1dBi): AWSS-507: band 470-547 MHz, AWSS-590: band 547-663 MHz, AWSS30-950: band 940-960 MHz.

This equipment complies has been evaluated for and shown compliant with the FCC and ISED RF Exposure limits. The unit of measurement for RF exposure is Specific Absorption Rate (SAR). The FCC SAR limits for is 1.6W/Kg per 1g of tissue. The maximum SAR levels tested has been shown to be 0.85 W/kg at head with 0mm of separation distance from the body.

This device operates on a no-interference, no-protection basis. Should the user seek to obtain protection from other radio services operating in the same TV bands, a radio license is required. For further details, consult Innovation, Science and Economic development Canada's Client Procedures Circular CPC-2-1-28, Voluntary Licensing of License-Exempt Wireless Microphones in TV Bands.

The FCC and IC identifier is visible in the display when the device is switched on and it is also available by accessing the Info>STD submenus.



## COMPLIANCE

Model	In compliance with	Range and max power	Country
MTP61-EU	EN 301 489-1/-9 EN 600065 EN 300 422-1/-2	470-832 MHz max 50 mW	Europe
MTP61-EUX*	EN 301 489-1/-9 EN 600065 EN 300 422-1/-2 EN 300 454-1/-2	470-832 MHz max 100 mW	Europe
MTP61-US	FCC PART 74 FCC-ID: POUUMTP61	470-608 MHz max 100 mW 614-663 MHz max 20 mW 940-960 MHz max 100 mW	USA
MTP61-CA	RSS-123, RSS-102 IC:11967A-MTP61	470-608 MHz max 100 mW 614-663 MHz max 20 mW 940-960 MHz max 100 mW	Canada
MTP61-JP1	MIC 217-231061	660-714 MHz max 10 mW	Japan
MTP61-JP2	MIC 217-231062	806-810 MHz max 10 mW	Japan
MTP61-JP3	MIC 217-231063	1240-1260 MHz max 50 mW	Japan
MTP61-KR	KC: R-C-WIY-MTP61	510-698 MHz max 100 mW 925-937,5 MHz max 10 mW	South Korea

The model "MTP61-xx" and conformity logos are shown on the external label and can be checked in the menu Info > STD (regulation standard).

**Before putting the device into operation, please observe the respective country-specific regulations!**

*\* MTP61-EUX is not an SRD device, thus it requires specific authorization by your local frequency authority!*

## SAFETY INSTRUCTION

- Read this safety instruction and the manual first
- Follow all instructions and information.
- Do not lose this manual.
- Do not use this apparatus under the rain or near the water.
- Do not install the apparatus near heaters or in hot environments, do not use outside the operating temperature range.
- Do not open the apparatus, only qualified service technician are enabled to operate on it. The apparatus needs servicing when it is not properly working or is damaged by liquids, moisture or other objects are fallen in the apparatus.
- Use only accessories or replacement parts authorized or specified by the manufacturer.
- Clean the apparatus only with dry cloths, do not use liquids.
- Report the serial number and the purchasing date in front of the manual. It is needed to have proper replacement parts or accessories from the manufacturer.
- When replacement parts are needed, use only replacement parts authorized from the manufacturer. Substitution with not authorized parts could result in electric shock, hazards or fire.
- Keep attention on all the labels with warnings or hazards on the apparatus.

**EU DECLARATION OF CONFORMITY**

We,

WISYCOM S.r.l.  
via Tiepolo, 7/E  
35019 Tombolo (PD) – Italy

declare under our sole responsibility that the product

*Model*  
*Description*

**MTP61**  
**Wireless Microphone Transmitter**

conforms to the essential requirements of the following European Directives and their associated norms:

Directive	Applicable Standards	Description
RADIO Directive 2014/53/EU (RED)	EN 300 422-1 v2.1.2	Wireless Microphones; Audio PMSE up to 3 GHz; Part 1: Class A Receivers; Harmonised Standard covering the essential requirements of article 3.2 of Directive 2014/53/EU
EMC	EN 301 489-1 v1.9.2	“ElectroMagnetic Compatibility (EMC) standard for radio equipment and services; Part 1: Common technical requirements; Harmonised Standard covering the essential requirements of article 3.1(b) of Directive 2014/53/EU and the essential requirements of article 6 of Directive 2014/30/EU
	EN 301 489-9 v2.1.1	ElectroMagnetic Compatibility (EMC) standard for radio equipment and services; Part 9: Specific conditions for wireless microphones, similar Radio Frequency (RF) audio link equipment, cordless audio and in-ear monitoring devices; Harmonised Standard covering the essential requirements of article 3.1(b) of Directive 2014/53/EU
Safety	EN 62368-1 2014	Audio/video, information and communication technology equipment — Part 1: Safety requirements (IEC 62368-1:2014, modified)
Human Exposure	EN 62311:2020	Assessment of electronic and electrical equipment related to human exposure restrictions for electromagnetic fields (0 Hz — 300 GHz)
RoHS	EN IEC 63000:2018	Technical documentation for the assessment of electrical and electronic products with respect to the restriction of hazardous substances

Date: August 28, 2023

Enzo Frigo, Technical Director

  
WISYCOM S.r.l.  
Via Tiepolo, 7/E - 35019 TOMBOLÒ (PD)  
Tel. +39 0424 382806 - Fax +39 0424 382733  
sales@wisyc.com - www.wisyc.com  
P.IVA (VAT) / C.F.: IT 02765640244





**WisyCom srl**

Via Tiepolo, 7/E  
35019 Tombolo (PD) – Italy  
VAT# IT02765640244

Tel. +39 0424 382605  
e-mail : [sales@wisyc.com](mailto:sales@wisyc.com)