

MAT244 User Manual

Programmable
RF Combiner



SN: _____

rev.01 (ref. FW 1.7)

Date: 08 November 2022

SAFETY INSTRUCTION

- Read this safety instruction and the manual first
- Follow all instructions and information.
- Do not lose this manual.
- Do not use this apparatus under the rain or near the water.
- Do not install the apparatus near heaters or in hot environments, do not use outside the operating temperature range.
- Mount the apparatus as indicated in the instruction, do not block side grids for air ventilation
- **ATTENTION:** supply the apparatus with a correct mains voltage and with the ground connection. Check the power cord integrity.
- The power cord must be protected from damage
- Do not install the apparatus near heaters or in hot environments, do not use outside the operating temperature range.
- Do not open the apparatus, only qualified service technician are enabled to operate on it. The apparatus needs servicing when it is not properly working or is damaged by liquids, moisture or other objects are fallen in the apparatus.
- Use only accessories or replacement parts authorized or specified by the manufacturer.
- Clean the apparatus only with dry cloths, do not use liquids.
- The ON/OFF is a double pole circuit breaker, but to ensure the complete disconnection of the apparatus, disconnect the power cord.
- Report the serial number and the purchasing date in front of the manual. It is needed to have proper replacement parts or accessories from the manufacturer.
- When replacement parts are needed, use only replacement parts authorized from the manufacturer. Substitution with not authorized parts could result in electric shock, hazards or fire.
- Keep attention on all the labels with warnings or hazards on the apparatus.

BRIEF DESCRIPTION

MAT244 is a programmable RF combiner, software configurable in:

- Combiner 8:1 with 7dB max gain (not diversity)
- Combiner 8:4 with 0dB max gain (not diversity)
- Diversity Combiner 4:2 with 7dB max gain

MAIN TECHNICAL FEATURES

- combiner 8:1 or 8:4 or 4:2 (sw configurable)
- Wide bandwidth **150-840 MHz** operation
- Remote management and monitor of alarms thru Ethernet 10/100 base TX
- Antenna booster on each inputs
- Programmable attenuators on each inputs
- Remote boost control (for gain/bandwidth) with a bidirectional data link thru coax (input BNC's)

QUICK START INSTRUCTION

1. Connect to the power outlet using the supplied power cable (see [rear panel](#))
2. Using coaxial cables withdraw the signal from BNC output connections (see [rear panel](#): 4 outputs w, x, y, z)
3. Plug the antennas to the relative input connectors (see [rear panel](#): A-B, 1 to 8 connectors)
4. Power on the MAT244
5. Switch off the unused areas/channels from the front panel
6. Choose the output option that best fits your needs. MAT244 is a programmable RF combiner, software configurable (*Setup > RF matrix* menu) in:
 - Combiner 8:1
 - Combiner 8:4
 - Diversity Combiner 4:2
7. Power the antenna booster from the main menu
8. Set the gain of antenna booster or the gain of the MAT244 in order
 - to have the same noise floor on all the areas (switch off all the TXs, check on MRK960 receiver the level of noise using the RF Test menu).
 - to coverage the required area (perform a Walk test with MRK960)
9. Enjoy our MAT244 versatility and reliability.

FRONT PANEL CONTROL AND FUNCTIONS

MAT244 allows an easy and quick configuration using buttons, push knobs and OLED display.



The front panel is functionally divided in the following section:

A – Lock/Unlock

To lock the MAT244 push the lock button in the front panel.

When the MAT is locked:

- the circle led upper the lock button is yellow lighted
- it is not possible to change any parameters on the status menu
- it is not possible to enable/disable the RF input with the square button

B – Input Channels status

Gives you details about the 8 input antennas divided between channel A and channel B.

Here you can check RF status, antenna DC power and antenna attenuation.

C - LCD display

64 x 254 yellow-lighted display. 3 push buttons (membrane). The function of each button (upper, middle and lower) will be readable from the context menu on the display.

D – Rotary Knob/Alarm indicator

Push rotary knob. Rotate and push to select. Warning (YELLOW) and Alarm (RED) light indicator

E – Matrix Leds

Link led shows the status of the host connection, Act the traffic and STA1/STA2 are the Ethernet interface's led.

F – Power AC

ON/OFF square powering button turns on/off the Matrix. When in OFF position both phases are disconnected from power.

REAR PANEL

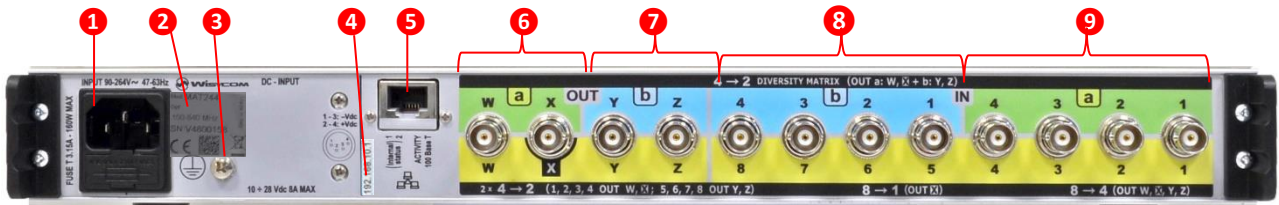

- 1 AC Power Plug** AC mains power input, IEC Connector 90-264 Vac
- 2 Product label** with Serial Number, Options and Bandwidth
- 3 Ground point** To connect the rack to ground
- 4 Label with IP address** of Ethernet interface configured on the MAT244 (it can be modified using the Manager application)
- 5 Ethernet socket** (RJ45) for connection to a network or computer
- 6 Output W, X, channel A**
- 7 Output Y, Z channel B**
- 8 Input 1-4 channel A**
- 9 Input 1-4 channel B or 4-8**

Status screen

After switch on, the matrix display the Status screen

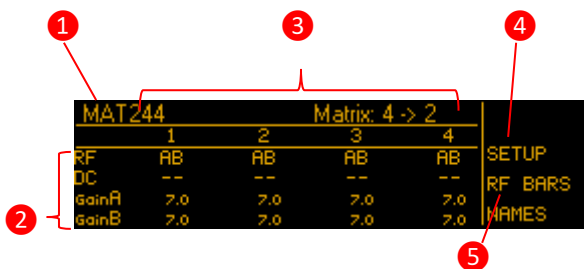

The main view has the following info:

- 1 Device name**
- 2 main setting:** RF, DC and attenuation parameters
- 3 Channels 1-4** (diversity) or 1-8
- 4 Setup menu** (RF Matrix, antennas diagnosis, display brightness, info,...)
- 5 RF bar menu** to check the reception status of channels A and B

Pushing the knob from the Status menu, it is possible to enter on the configuration setting of each input port:

ports 1÷4 (diversity configuration 4->2) or ports 1÷8 (no diversity configuration, 8->1 or 8->2) **2**

For each port it is possible to:

- ◆ enable **RF input** (only in diversity configuration 4->2)
 - both A&B ports (**AB**)
 - only A (**A-**)
 - only B (**-B**)



NOTE: push the square button to disable RF input of both the ports (A & B): the button becomes unlighted.

- ◆ enable power supply **DC (12V/250mA)** to antenna booster

Configuration 4->2		Configuration 8->1 or 8->4	
AB	DC enabled on both ports A&B	N	DC enabled
A-	DC enabled only on port A	-	no DC enabled
-B	DC enabled only on port B		
--	no DC enabled		

- ◆ enable power supply **DC with extra current (12V/800mA)** ex. BAW
ONLY FOR PORT1 and PORT5

Configuration 4->2 Port 1a and Port 1b		Configuration 8->1 or 8->4 Port 1 and Port 5	
HH	DC with extra current enabled on ports 1a and 1b	H	DC with extra current enabled on port 1 or port 5
H-	DC with extra current enabled on port 1a		
-H	DC with extra current enabled on port 1b		
HB	DC with extra current enabled on port 1a and standard DC on port 1b		
AH	DC with extra current enabled on port 1b and standard DC on port 1a		

According to the DC antenna booster setting, the square button in the front panel can be



- lighted fixed blue (**AB**) or (**N**)
- lighted flashing blue for 5 sec, then fixed blue (**A-** or **-B**)



- lighted fixed green (**--**)

- ◆ change the gain/attenuation on antenna A or B (from 7 to 24.5 dB, step 0.5)

SETUP MENU

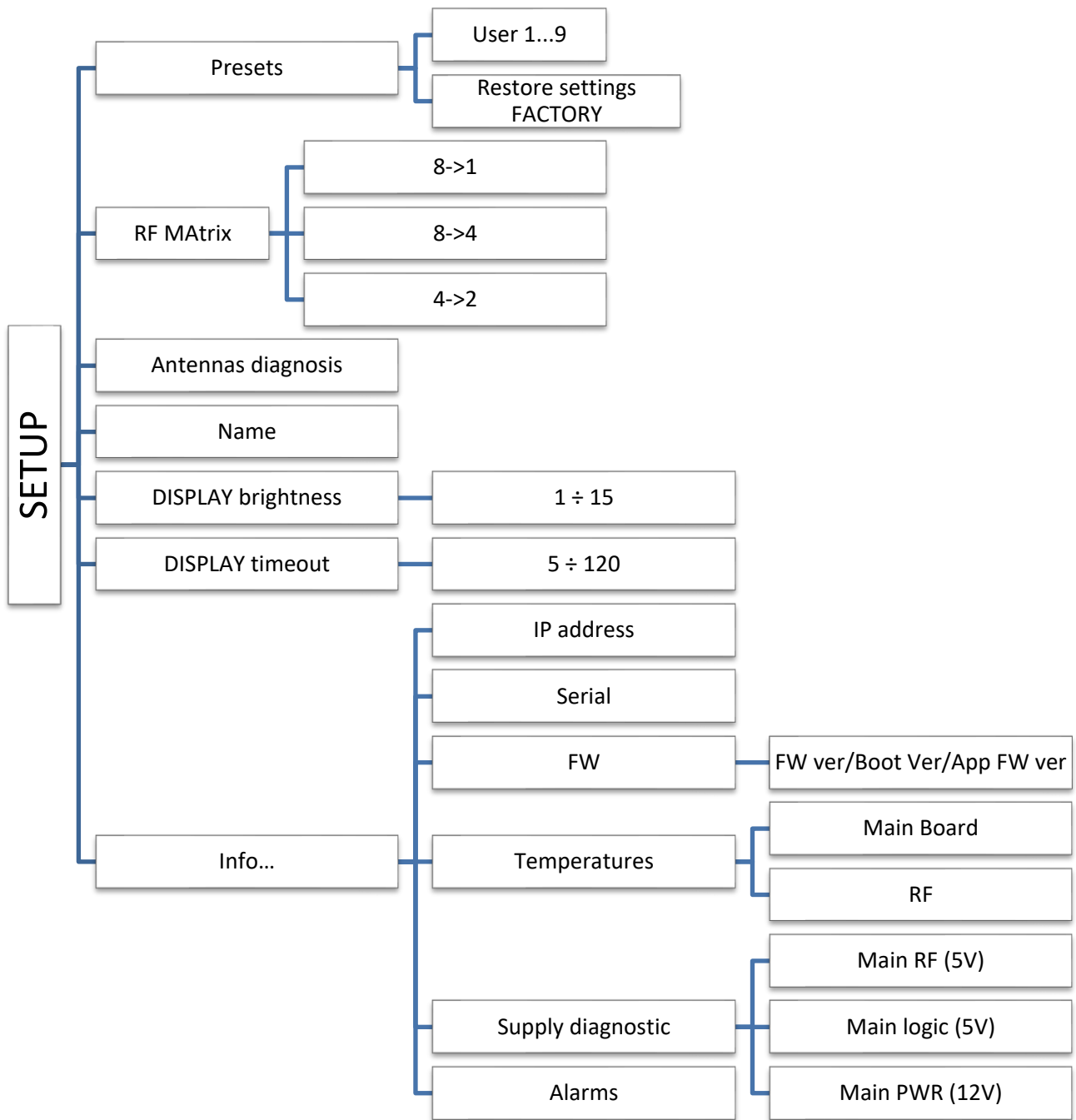

RF Matrix

MAT244 is a programmable RF combiner. By entering into RF Matrix menu you can configure the software picking one of the three following options:

- Combiner 8:1 with 7dB gain max
- Combiner 8:4 with 0dB gain max
- Diversity Combiner 4:2 with 7dB gain max



Antennas Diagnosis

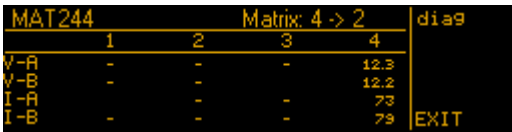

This submenu allows you to check the value levels of voltage (V) and current (I) of the 8 antennas of MAT244.

Name

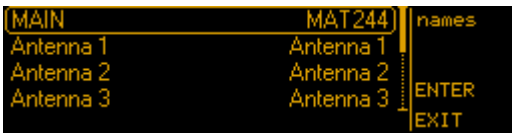

The NAME submenu let you change the name of your matrix that will be visible on the status menu and the name of the Areas that will be visible on the monitoring by Wisycom Manager:

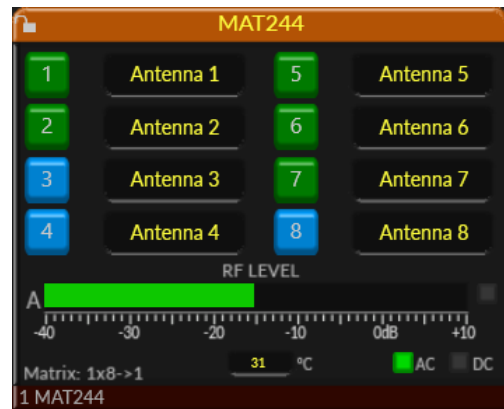

Display brightness and display timeout

In these two menus you can increase or decrease display brightness or modify the time before the display turns darker.

Info

Here you can check all the basic info about your MAT244 such as IP address, serial number, Firmware, alarms etc.

RF BAR MENU

It shows the current measured RF levels and the peak levels of areas.

diversity configuration 4->2

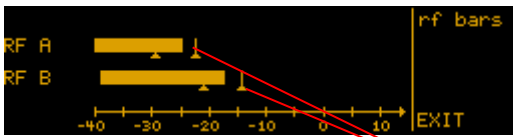

configuration 8->1 or 8->4

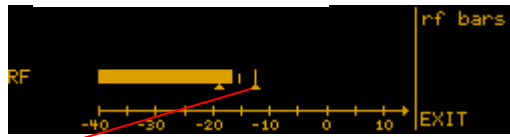

peak levels

RF level are wideband measurement and show the maximum power level measured from 150-840MHz

Peak levels are reset whenever you go back to the RF BAR menu.

NOTE: 0 level corresponds to -20dBm (approx.. 85dBμV)

Example of configurations:

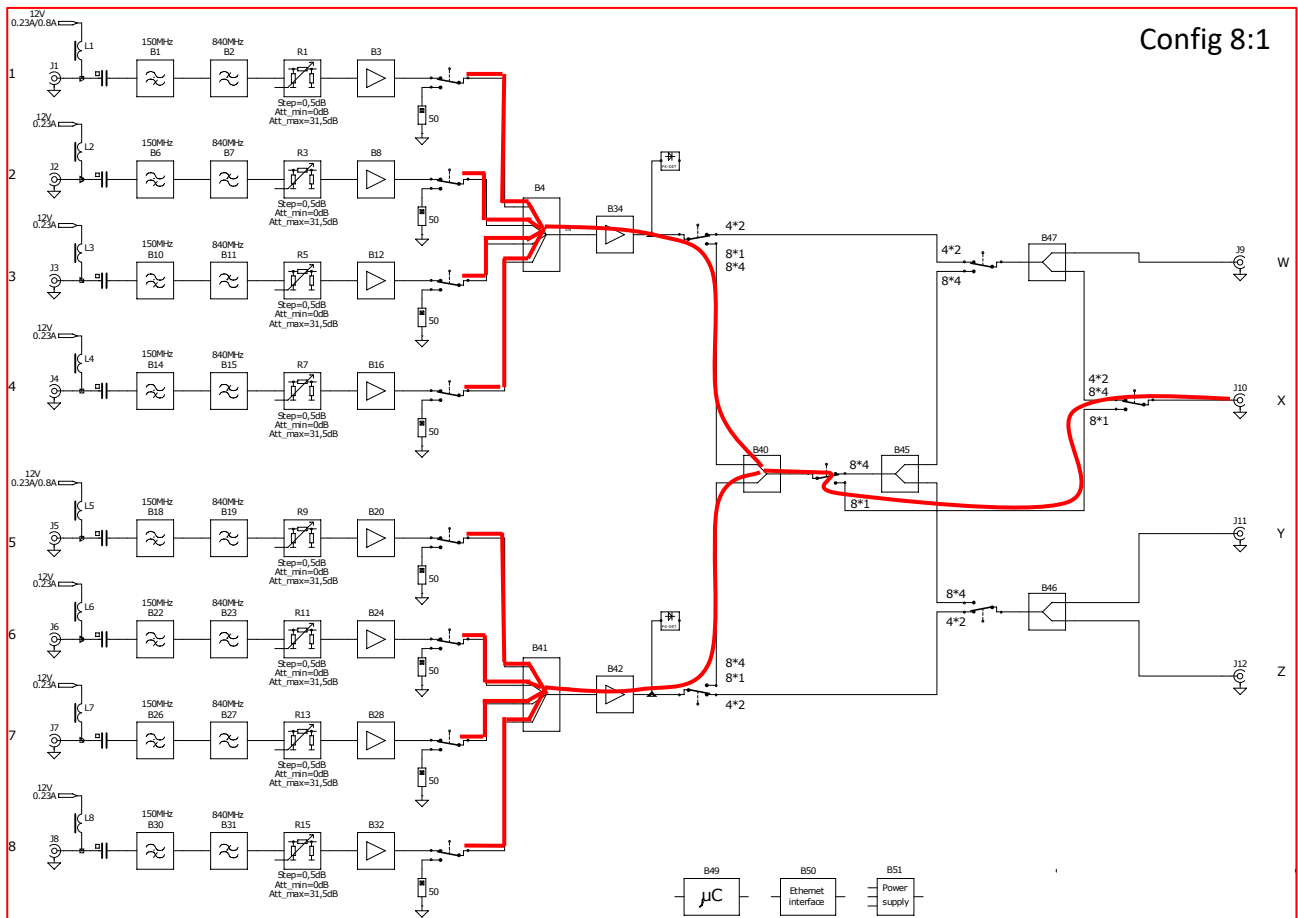

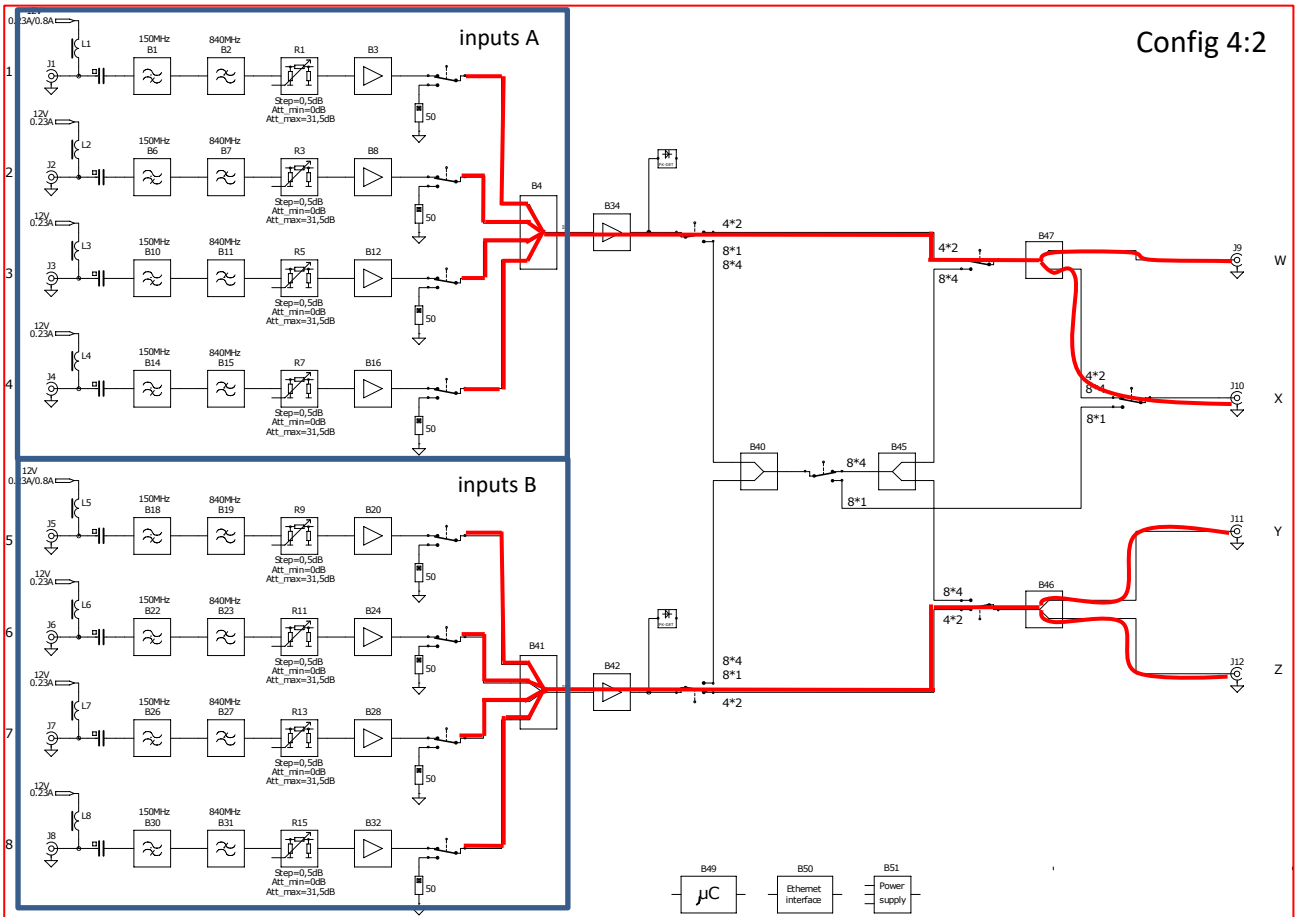
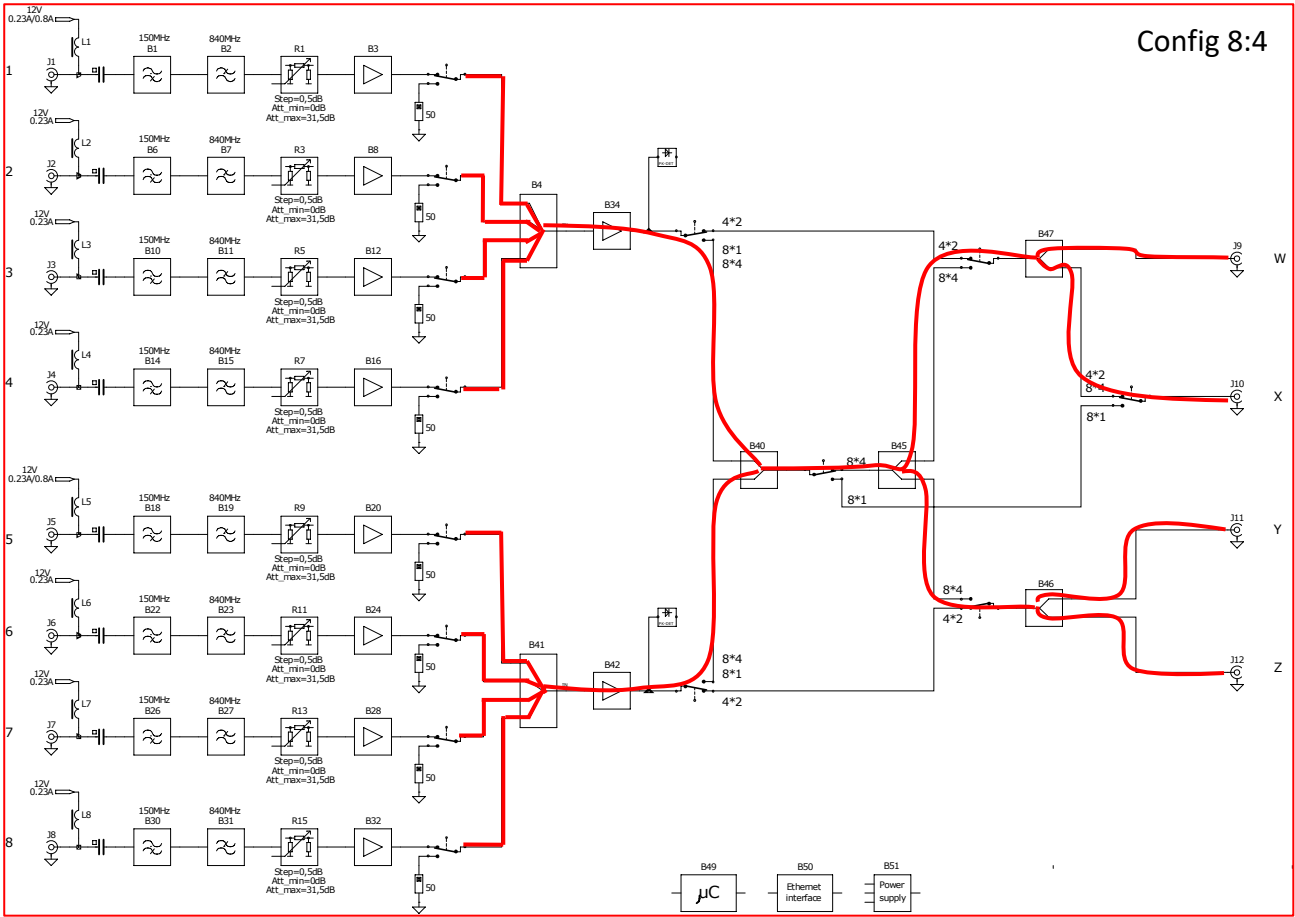

ALARM LIST

When an alarm occurs, the MAT244 advises you with one or more of the following acts:

A. Show a message on the display



B. Turn on the yellow or red alarm led



C. Insert the alarm on the alarm list in the [MAIN>Options>Info>Alarms menu](#)

Shown below the complete alarms list:

Message on display (A)	Type	Alarm List (C)	Led (B)	Aux Led
Invalid Calibration Memory	Gen	Invalid calibration memory	Fixed Red	---
Calibration data copy #1 invalid	Gen	Cal. Data copy 1 invalid	Fixed Yellow	---
Calibration data copy #2 invalid	Gen	Cal. Data copy 2 invalid	Fixed Yellow	---
Calibration data copies differ	Gen	Calibration data copies differ	Fixed Red	---
System boot failed	Gen	---	Fixed Red	---
Internal high temperature	Gen	High temperature	Fixed Red	TEMP Fast Blinking
Communication error on I2C bus #0	Gen	I2C bus #0	Fixed Red	---
Communication error on I2C bus #1	Gen	I2C bus #1	Fixed Red	---
Temperature main board sensor doesn't communicate	Gen	Temp. main board sensor comm.	Slow Blinking Red	---
Temperature RxA board sensor doesn't communicate	Gen	Temp. RxA board sensor comm.	Slow Blinking Red	---
Temperature RxB board sensor doesn't communicate	Gen	Temp. RxB board sensor comm.	Slow Blinking Red	---
Eth rx busy	Gen	Eth rx busy	Fixed Red	---
Error updating calibration copy crc	Gen	Cal copy crc update error	Fixed Red	---
Fan #1 doesn't work properly	Gen	Fan #1	Fixed Yellow	FAN1 Fast blinking

Fan #2 doesn't work properly Antenna nA: DC overload Antenna nB: DC overload	Gen	Fan #2	Fixed Yellow	FAN2 Fast blinking
	Anten	Antenna nA: DC overload	---	Antenna N
	Anten	Antenna nB: DC overload	---	Antenna N

TECHNICAL SPECIFICATION

Power supply	: AC connector 90÷264Vac / T2A, 47÷63Hz
Working frequency	: 150 ÷ 840 MHz
Amplifier linearity	: ± 1 dB (typical)
“A” / “B” antenna input	: 8 BNC type connector
antenna output	: 4 BNC type connector
Impedance	50 Ω
Input/output Gain	7 dB (combiner 8:1), OIP3=30dBm typ. 0 dB (combiner 8:4), OIP3=24dBm typ. 7 dB (diversity combiners 4:2), OIP3=30dBm typ
Noise Figure	5.5dB (each channel)
Antenna booster powering	+12Vcc / 800mA MAX.(ports 1a, 1b) +12Vcc / 230mA MAX.(other ports)
Configuration/monitor interfaces	: 10/100 Base TX Ethernet port
Display	: 64 x 256 OLED (yellow)
Dimension	: Standard rack (aluminum) 19” / 1U.
Weight	: 3,7 Kg

Type approvals

In compliance with

CE EN 301 489-1/-9
EN 600065
EN 300 422-1/-2

FCC 47 CFR 15 Subpart B

Statements regarding FCC and Industry Canada

This device complies with part 15 of the FCC Rules and RSS-210 of Industry Canada. Operation is subject to the following two conditions:

- (1) This device may not cause harmful interference, and
- (2) This device must accept any interference received, including interference that may cause undesired operation.

In compliance with

FCC 47 CFR 15 Subpart B

CAN RSS-Gen/CNR-Gen

ENVIRONMENTAL INFORMATION

Applicable in the European Union and other European countries with separate collection systems

Disposal of Old Electrical & Electronic Equipment (2002/96/EC)

This symbol indicates that this products shall not be treated as household waste. Instead it shall be handed over to the appropriate collection point for the recycling of electrical and electronic equipment. The recycling of material will help to conserve natural resources.

ITALY ONLY

Obblighi di informazione agli utilizzatori

ai sensi dell'art. 13 del Decreto Legislativo 25 luglio 2005, n. 151 "Attuazione delle Direttive 2002/95/CE, 2002/96/CE e 2003/108/CE, relative alla riduzione dell'uso di sostanze pericolose nelle apparecchiature elettriche ed elettroniche, nonché allo smaltimento dei rifiuti"

Smaltimento di apparecchiature elettriche ed elettroniche di tipo professionale

Il simbolo del cassonetto barrato riportato sull'apparecchiatura o sulla sua confezione indica che il prodotto alla fine della propria vita utile deve essere raccolto separatamente dagli altri rifiuti.

La raccolta differenziata della presente apparecchiatura giunta a fine vita è organizzata e gestita dal produttore. L'utente che vorrà disfarsi della presente apparecchiatura dovrà quindi contattare il produttore e seguire il sistema che questo ha adottato per consentire la raccolta separata dell'apparecchiatura giunta a fine vita.

L'adeguata raccolta differenziata per l'avvio successivo dell'apparecchiatura dismessa al riciclaggio, al trattamento e allo smaltimento ambientalmente compatibile contribuisce ad evitare possibili effetti negativi sull'ambiente e sulla salute e favorisce il reimpiego e/o riciclo dei materiali di cui è composta l'apparecchiatura.

Lo smaltimento abusivo del prodotto da parte del detentore comporta l'applicazione delle sanzioni amministrative previste dalla normativa vigente.

Iscrizione al Registro A.E.E. n. IT09100000006319



EU DECLARATION OF CONFORMITY

We,

WISYCOM S.r.l.
via Tiepolo, 7/E
35019 Tombolo (PD) – Italy

declare under our sole responsibility that the product

Model
Description

MAT244, MAT288
Matrix Antenna Combiner

conforms to the essential requirements of the following European Directives and their associated norms:

Directive	Applicable Standards	Description
RADIO Directive 2014/53/EU (RED)	EN 300 422-1 v2.1.2	Wireless Microphones; Audio PMSE up to 3 GHz; Part 1: Class A Receivers; Harmonised Standard covering the essential requirements of article 3.2 of Directive 2014/53/EU
EMC	EN 301 489-1 v1.9.2	“ElectroMagnetic Compatibility (EMC) standard for radio equipment and services; Part 1: Common technical requirements; Harmonised Standard covering the essential requirements of article 3.1(b) of Directive 2014/53/EU and the essential requirements of article 6 of Directive 2014/30/EU
	EN 301 489-9 v2.1.1	ElectroMagnetic Compatibility (EMC) standard for radio equipment and services; Part 9: Specific conditions for wireless microphones, similar Radio Frequency (RF) audio link equipment, cordless audio and in-ear monitoring devices; Harmonised Standard covering the essential requirements of article 3.1(b) of Directive 2014/53/EU
Safety	EN 62368-1 2014	Audio/video, information and communication technology equipment — Part 1: Safety requirements (IEC 62368-1:2014, modified)
RoHS	EN IEC 63000:2018	Technical documentation for the assessment of electrical and electronic products with respect to the restriction of hazardous substances

Date: 8 November 2022

Enzo Frigo, Technical Director

WISYCOM S.r.l.

Via Tiepolo, 7/e - 35019 TOMBOLO (PD)
Tel. +39 0424 382605 - Fax +39 0424 382733
sales@wisyc.com - www.wisyc.com
P.IVA (VAT) / C.F.: IT 02765640244



Via Tiepolo 7/E • 35019 Tombolo (PD) • Italy
Tel. +39 -0424 -382605 • Fax +39 - 0424 - 382733
www.wisycom.com • e-mail: sales@wisycom.com