



**ADMIRAL**  
STAGING

Original user manual

# TRUSS BRACKET 30 WITH U-BOLTS



Manufacturer:

**Rolight Theatertechniek B.V.**

Josink Kolkweg 10

7545 PR Enschede, The Netherlands

Phone (+31)53 432 06 44

info@rolight.nl

www.rolight.nl

Distributed by ADMIRAL

VERSION 01  
July 2024  
SKU: RIHBAD35

[www.admiralstaging.com](http://www.admiralstaging.com)

# CONTENT

1. INTRODUCTION
2. SAFETY INSTRUCTIONS
3. SCOPE
4. LIMITATIONS OF USE
5. TECHNICAL DATA & LOADCHART
6. IDENTIFICATION
7. EXPLANATION OF THE ENGRAVING
8. ASSEMBLY INSTRUCTIONS
9. DISASSEMBLY INSTRUCTIONS
10. STORAGE
11. MAINTENANCE & REJECTION CRITERIA
12. WARRANTY
13. EC DECLARATION OF CONFORMITY

## 1. INTRODUCTION

The ADMIRAL TRUSS BRACKET 30U is a truss accessory to be used as lifting point in temporary or permanent installations. For ease of reading, the wording “TRUSS BRACKET 30U” is used to replace the full product name “Truss bracket 30 with U-bolts”.

In this manual ELL stands for Entertainment Load Limit. Meaning the device has a inherent double safety factor (8:1) and is therefore suitable to suspend and lift loads above persons. The TRUSS BRACKET 30U is also designed to meet the German regulation for loads above persons DGUV17/18 (formerly known as BGVc1).

ADMIRAL has endeavoured to deliver the highest degree of accuracy possible. However continuous improvement of our products is ADMIRAL policy. Therefore product specifications are subject to change without notice. Readers and users are encouraged to notify ADMIRAL of errors and send in suggestions for improvements. All communications will be carefully considered for future printings of this manual and changes to our products.

## 2. SAFETY INSTRUCTIONS

This user manual must be read and understood prior to assembly, setup and servicing. All people using and servicing the TRUSS BRACKET 30U must familiarise themselves with the safety instructions and user guidelines written in this manual. This manual needs to be accessible for all users at all times.

## LEGEND



### DANGER

**DANGER:** Indicates a hazardous situation which, if not avoided, will result in death or serious injury. This signal word is to be limited to the most extreme situations.



### WARNING

**WARNING:** Indicates a hazardous situation which, if not avoided, could result in death or serious injury.



### CAUTION

**CAUTION:** Indicates a hazardous situation which, if not avoided, could result in minor or moderate injury.

### NOTICE

**NOTICE:** Addresses practices not related to personal injury.

### SAFETY INSTRUCTIONS

**SAFETY INSTRUCTIONS:** Is used for lists of steps, procedures or instructions that might otherwise substitute a DANGER, WARNING or CAUTION notification. Note that equivalent phrases, such as SAFE OPERATION PROCEDURES or SAFE SHUT DOWN PROCEDURE, can be used in place of the words “SAFETY INSTRUCTION”.



## CAUTION

- A TRUSS BRACKET 30U must be taken out of service immediately if, during use, repair or maintenance damages are discovered.
- Remove people from the area during installation.
- Use solely instructed and/or trained personnel.
- Wear appropriate Personal Protective Equipment (PPE) such as hard hats and gloves during installation.
- Make sure there is adequate amount of working light during installation of the product.

## 3. SCOPE

The intended use of the TRUSS BRACKET 30U is to create a lifting point for trusses for permanent or temporary installations within the entertainment industry.

The TRUSS BRACKET 30U is suitable for truss with a centre-to-centre main chord distance of 239 mm  $\pm$  1.5 mm (30 truss) and has a load capacity of ELL 500 kg.

Any other way of use is considered to be a case of misuse. Solely the user is liable for any damage or injury resulting from such cases.

## SAFETY INSTRUCTIONS

Check local legislation for the application of use.

## 4. LIMITATIONS OF USE



### WARNING

Exceeding the limitations of use can severely endanger the audience and users.



### WARNING

Dynamic factor of lifting must be considered separately.

- The TRUSS BRACKET 30U can be operated from -20° up to 60° Celsius.
- Do not exceed the maximum ELL (entertainment load limit) stated on the product.
- Make sure the resulting forces on the supporting structure are approved by a competent person before applying the load.
- To determine the maximum suspended load on the product, all imposed loads shall be considered. e.g. the dynamic factor caused by the lifting machinery.
- Sound systems can be suspended but users must check regular the integrity of the clamp as severe vibrations could loosen bolts / knobs .
- The TRUSS BRACKET 30U must be inspected by a competent person as often as required but with a minimum of 1 x per year. Records of these inspections must be kept.
- Inspect equipment before every use. A damaged TRUSS BRACKET 30U shall be taken out of service.
- Outdoor use shall be approved by a competent person and might influence the load capacity. Do not expose the product to full rain or snow. Outdoor use is the sole responsibility of the operator.
- In case of use in the vicinity of saltwater, the product shall be rinsed regularly with fresh water to avoid corrosion.
- It is also imperative to observe the local accident prevention regulations and/ or occupational health and safety regulations.
- The support structure, on which the TRUSS BRACKET 30U is used, must have lightning protection when used outdoors.

- The support structure, on which the TRUSS BRACKET 30U is used, might need to have electric potential bonding.
- Do not use the TRUSS BRACKET 30U to guide currents for electric potential bonding.
- Make sure the TRUSS BRACKET 30U and the supporting structure are dry and free of dirt.
- Use appropriate packaging to transport the products. e.g. a flightcase.
- Solely use by ADMIRAL approved parts to replace damage or lost parts.
- Do not re-zinc steel components as they might be subject to hydrogen embrittlement.

### WARNING

Do not apply eccentric loading (fig 01) but medial (fig 02).

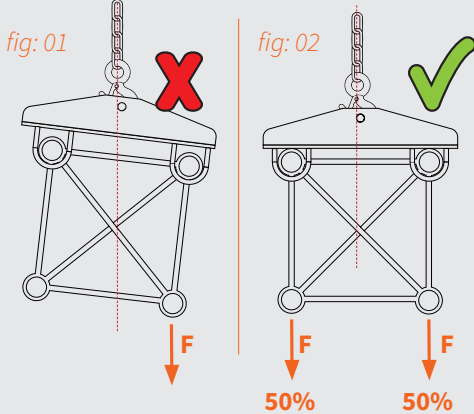

### WARNING

The allowable load from the TRUSS BRACKET 30U strongly depends on the total supporting structure. A load that is too heavy can cause the structure to fail.

### CAUTION

Do not throw the TRUSS BRACKET 30U, as it might damage the product.

### WARNING

Do not suspend the TRUSS BRACKET 30U as shown below (fig 01). It creates torsional forces and influences the overall strength and stability.

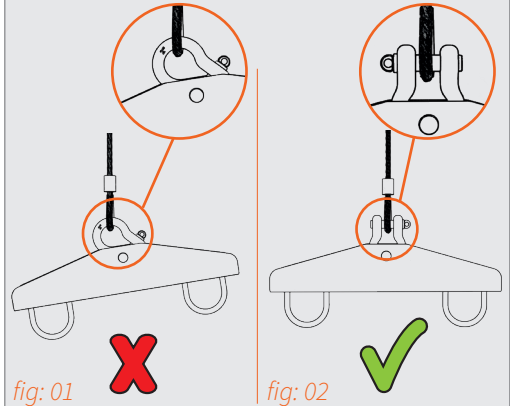

### WARNING

Make sure the TRUSS BRACKET 30U is placed in a vertical position. Do not exceed an angle of max. 6° when lifting the truss construction.

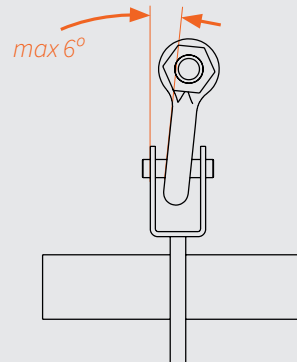

## 5. TECHNICAL DATA & LOADCHART

### Applicable Directives, Regulations, Standards and Information Papers

Top view

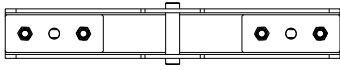

**ELL**  
**500Kg**

Front view

Side view

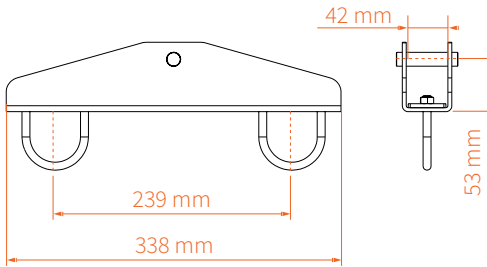

### Technical data

Article code:	RIHBAD35
EAN:	8720094420646
ELL:	500 kg
Safety factor against failure:	8:1
Material:	steel
Finish:	powder coated
Dimensions:	338 x 62 x 162 mm (L x W x H)
Weight:	1.57 kg
Colour:	black gloss 30% (RAL 9005)

### The following directive is applicable

2006/42/EC

Machinery directive

### The following regulation is used

DGUV regulation 17

Regulations for stages and studios

(Formerly known as BGVc1)

### Parts of the following standards and information papers are used

DGUV Information

Safety at productions and events for television, radio, film, theatre,

215-313

exhibitions: Loads above persons

(Formerly known as BGI 810-3)

EN 17206:2020

Lifting and load bearing equipment for stages and other production areas within the entertainment industry

BS 7905-1:2001

Lifting equipment for performance broadcast and similar applications. Part 1 specifications for the design and manufacture of above stage equipment

## 6. IDENTIFICATION

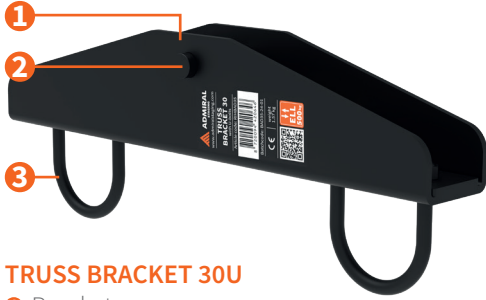

### TRUSS BRACKET 30U

- 1 Bracket
- 2 Pin
- 3 U-bolts

## 7. EXPLANATION OF THE STICKER

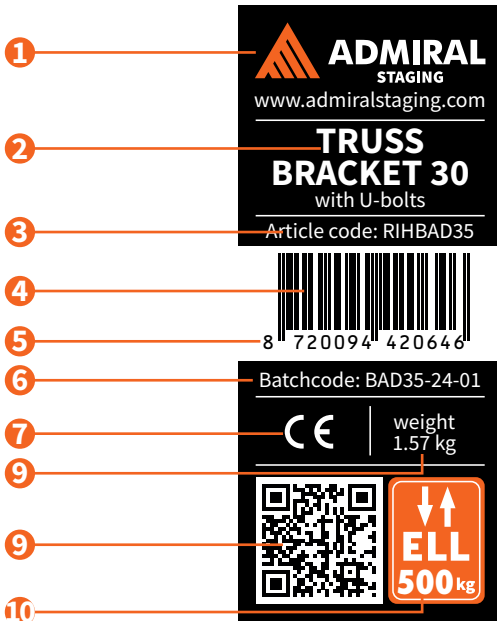

### TRUSS BRACKET 30U sticker

- 1 Brand name
- 2 Product name
- 3 Article code
- 4 Barcode
- 5 EAN code
- 6 Batchcode\*
- 7 CE Marking
- 8 Weight
- 9 QR code to online manual
- 10 Entertainment Load Limit

\*Based on the Batchcode ADMIRAL is able to trace the date of manufacturing

## 8. ASSEMBLY INSTRUCTIONS

### WARNING

Inspect the TRUSS BRACKET 30U before use. Make sure all components are in place and in good order. If damaged, mark the item clearly and take out of service.

### Step 1

Place the truss structure on the ground.

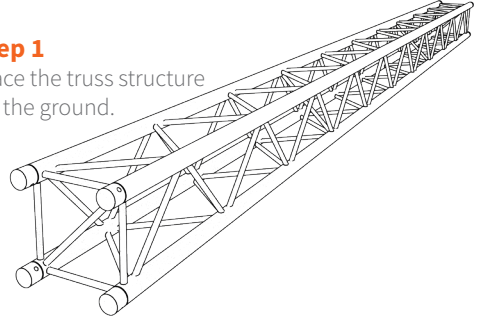

### Step 2

Grab the TRUSS BRACKET 30U and the U-bolts.

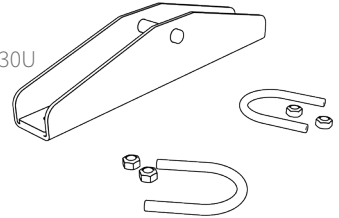

### Step 3

Place the TRUSS BRACKET 30U on the truss structure as close as possible to the but preferably in the node point. Ensure that the TRUSS BRACKET 30U is aligned correctly to distribute forces evenly within the truss structure.

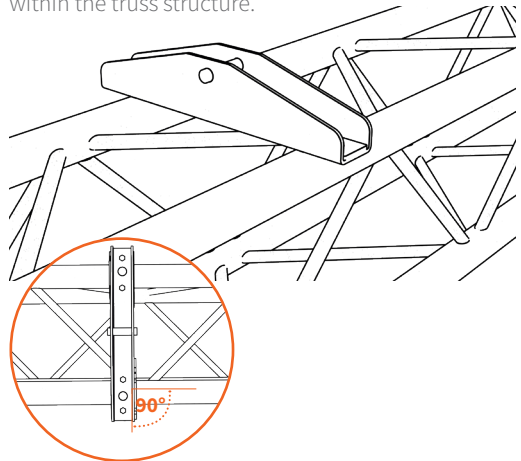

#### Step 4

Position the U-bolts around the truss and insert them through the holes in the TRUSS BRACKET 30U.

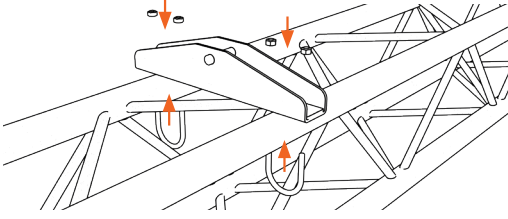

#### Step 5

Secure the nut onto the threads of the U-bolt and tighten it with a torque setting of 15 Nm.

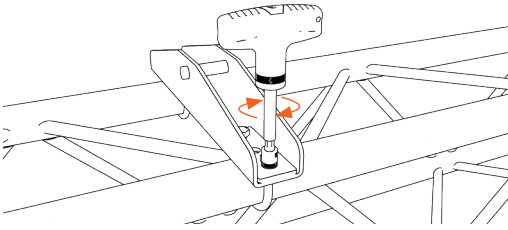

#### Step 6

Connect the TRUSS BRACKET 30U to the hoist using a certified shackle with a minimum ELL of 500 kg and a bow opening of 15 mm minimum.

Unscrew the shackle pin and place the bow around the pin (a). Insert the certified wire rope between the ears (b), and connect the parts by placing the shackle pin in the bow and tightening it with 25 Nm.

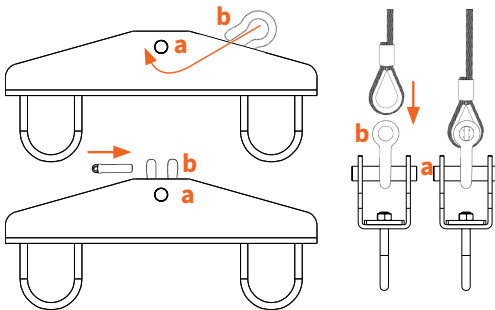

Alternatively, connect the TRUSS BRACKET 30U to the lifting hook. Open the hook, place the pin (a) of the TRUSS BRACKET 30U in it and secure the hook again.

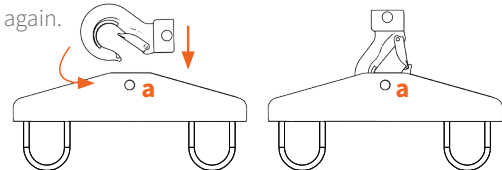

## WARNING

Check the integrity of the TRUSS BRACKET 30U after severe vibrations caused by e.g. sound or wind.

## 9. DISASSEMBLY INSTRUCTIONS

### Step 1

Lower the truss construction all the way down. Ensure that the wire rope or chain have slack.

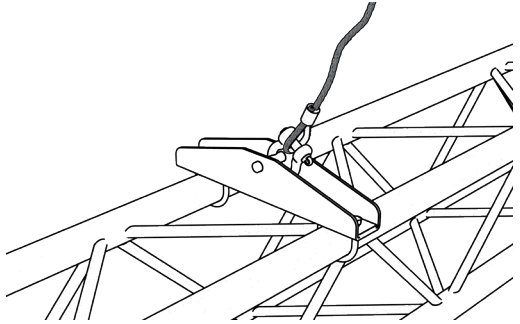

### Step 2

Untighten the hoist from the TRUSS BRACKET 30U.

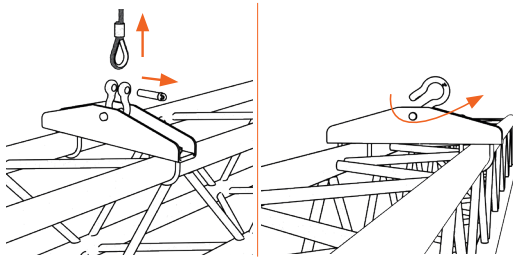

### Step 3

Disconnect the TRUSS BRACKET 30U from the truss structure.

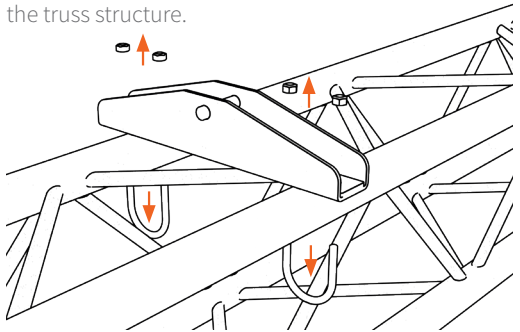

#### Step 4

Tighten the U-bolts to prepare the product for storage.

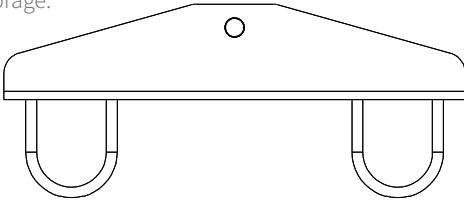

## 10. STORAGE

The TRUSS BRACKET 30U must be stored in a dry, non-aggressive environment.

- Make sure the parts cannot bend.
- Avoid vibrations. Rubbing parts can cause excessive wear and tear.

## 11. MAINTENANCE & REJECTION CRITERIA

### SAFETY INSTRUCTIONS

The TRUSS BRACKET 30U hardly needs any maintenance under normal use and environmental circumstances. For safety reasons however, all parts must be checked regularly for dirt, damages, loss and corrosion.

The TRUSS BRACKET 30U shall be checked in compliance with the local law by a competent person. Checking shall take place as often as required but with a minimum of 1x per year. In case of doubt contact ADMIRAL Staging.



### WARNING

If damaged, mark the item clearly and take it out of service.

- Missing or damaged parts shall be replaced by genuine Admiral components solely.
- Check all components for damages like cracks, deformations, scratches and corrosion. Damaged and corroded parts shall be rejected and thrown away.
- In general, scratches > 10% of the wall thickness mean the products needs to be rejected from use.
- In general, deformations > 10% of a straight line from the outer surface mean the products needs to be rejected from use.
- Remove all sharp and rough feeling edges and surfaces by using sand paper or a file.
- Check all welds for cracks. If cracked, replace.



## 12. WARRANTY

- For a period of 24 months we will repair, free of charge, any damage attributable to faulty materials or workmanship under the condition that the equipment is forwarded, freight paid, to our warehouse or one of the ADMIRAL Staging distributors' warehouses.
- The warranty-period begins with the day of the delivery, proven by a purchase receipt like an invoice or delivery note or their copies.
- The warranty does not cover damage due to transport, negligent handling, overloading the equipment or parts subject to normal wear and tear signs. Nor damages that originate from a case of misuse because of nonobservance of the safety regulations in this instruction manual.
- The warranty will be invalid when other parts than the original ADMIRAL Staging parts have been used or modifications of our design have been made by third parties.
- Warranty repairs do not renew nor extend the warranty-period.
- In case of a claim that falls under the warranty, e.g. a malfunction or spare part requirements please contact your point of sale or ADMIRAL Staging.
- The manufacturer is not liable for indirect consequential damage and financial loss.
- The manufacturer shall not be liable for any changes made to the TRUSS BRACKET 30U parts nor for any damage resulting from such changes.

# 13. EC DECLARATION OF CONFORMITY



## EC-DECLARATION OF CONFORMITY FOR MACHINERY (2006/42/EG Annex II)

We

Rolight Theatertechniek  
Josink Kolkweg 10  
7545 PR Enschede  
The Netherlands

Herewith declares that for :

Admiral "TRUSS BRACKET 30U"; Article code RIHBAD35

- is in compliance with the Machinery Directive 2006/42/EC annex II
- the following harmonized standards have been applied (or parts/clauses of): EN 12100-1-2010,
- the following technical regulations , standards and information papers have been used (parts/clauses of): German DGUV 17-18, German DGUV 215-313, EN 10204:2004, EN 17206 :2020, BS 7905-1 :2001, EN 1993, EN 1999

Enschede , The Netherlands 25 July 2024

Ms. E. Dijk  
Owner Rolight Theatertechniek b.v.



**Rolight**

